



**Prince George's County
Department of Environmental Resources**

**Standard Details
for Stormwater
Mangement
Construction**

January 2001

TABLE OF CONTENTS

CONVENTIONAL SYMBOLS.....	SD 1.0
CONVENTIONAL SYMBOLS.....	SD 1.1
TYPE "A" INLET	SD 10.0
TYPE "A" PRECAST INLET	SD 10.0
TYPE "B" INLET	SD 11.0
TYPE "B" PRECAST INLET	SD 12.0
TYPE "B" PRECAST INLET	SD 12.1
TYPE "B" PRECAST INLET TROUGH.....	SD 12.3
TYPE "CI" AND "C-I-P" INLET.....	SD 13.0
TYPE "D1" AND "D2" INLETS	SD 14.0
TYPE "D" INLET GRATE	SD 14.1
PRECAST YARD INLET.....	SD 15.0
TYPE "E" INLET	SD 16.0
TYPE "K" PRECAST INLET	SD 17.0
TYPE "A" MASONRY MANHOLE	SD 20.0
TOP SLAB FOR TYPE "A" PRECAST MANHOLE	SD 21.0
TYPE "A" DIA. PRECAST MANHOLE FOR 12"-24" PIPES	SD 21.1
TYPE "A" 60" DIA. PRECAST MANHOLE FOR 27"-36" PIPES....	SD 21.2
TYPE "A" 72" DIA. PRECAST MANHOLE FOR 42"-48" PIPES..	SD 21.3
TYPE "A" 84" DIA. PRECAST MANHOLE FOR 54" -66" PIPES..	SD 21.4
TYPE "A" 96" DIA. PRECAST MANHOLE FOR 72" PIPE.....	SD 21.5
TYPE "B" PRECAST SHALLOW MANHOLE.....	SD 22.0

STORM DRAIN ENDWALL.....	SD 30.0
TYPE "A" HEADWALL FOR 48" AND 60" PIPE	SD 31.0
TYPE "B" HEADWALL FOR 66" 72" 78" 84" DIA. PIPES	SD 32.0
TYPE "H" ENDWALL	SD 33.0
TYPE "H" ENDWALL QUANTITY TABLE	SD 33A.0
PRECAST CONCRETE END SECTION ROUND PIPE	SD 34.0
CUTOFF WALL AND OUTFALL DETAIL	SD 35.0
CHAIN LINK FENCE DETAIL	SD 40.0
FIELD CONNECTION FOR RCP	SD 50.0
INFILTRATION SYSTEM DETAIL	SD 70.0
MANHOLE AND <u>INLET STEPS</u> IN CHANNELS	SD 80.0
COPOLYMER POLYPROPYLENE STEEL ENCAPUSLATED LADDER RUNG	SD 81.0
SIGN STENCIL	SD 82.0
ACCESS ROAD GATE	SD 83.0
MANHOLE FRAME AND COVER (NON-TRAFFIC AREA).....	SD 90.0
MANHOLE RING AND COVER (TRAFFIC AREA)	SD 90.1
FRAME & COVER FOR 6' AND 7' DIA. MANHOLE TRAFFIC AREA	SD 90.2
CONCRETE ANCHOR FOR 15" TO 30" PIPES	SD 100.0
MANHOLE FRAME AND COVER (TRAFFIC AREA)	SD 90.3
BEDDING AND TRENCH WIDTHS FOR PIPE	SD 130.0
CONCRETE & ENCASEMENT CRADLE DETAILS	SD 150.0

EXISTING CONDITIONS

WSSC BOUNDARIES	
OTHER PROPERTY LINES	
COUNTY BOUNDARY	
STREET OR LOT LINES	
WOODEN FENCE	
CHAIN LINK, WIRE, BARB OR SMOOTH IRON FENCE	
HEDGE ROW	
STONE, BRICK OR CONCRETE WALL	
DIRT CURB, SLOPING INTERSECT OR DITCHES	
CURB AND SIDEWALK LINES	
CULVERT OR MISCELLANEOUS DRAINS	
GAS MAIN	
GAS DRIP, GAS VALVE OR DRIP POT	
GAS METER	
OVER HEAD POLES AND TOWERS	
OVERHEAD ELECTRIC LINES	
UNDERGROUND TELEPHONE	
UNDERGROUND TELEGRAPH	
BURIED CABLE	
UNDERGROUND ELECTRIC LINES	
TREES	
EARTH; SAND, GRAVEL, SHELL OR BROKEN STONE ROADS	
WATER BOUND, MACADAM, CONCRETE, BRICK ETC. ROADS	
COMBINATION ROADS	
RAILROAD	
STREAM/DITCH	
MARSH	
SIGN POST	
SOIL BORING SITES	
TRIANGLE STATION U.S.	
CONTROL STATION WSSC	
STAKE WITH TACK CENTER	
STAKE WITHOUT TACK CENTER	
IRON PIPE WITH CENTER	
IRON PIPE	
BENCH MARK	
NAIL, SPIKE OR IRON ROD	
DESCRIBED TURNING POINT	
EXCAVATION OR CUT	
EMBANKMENT OR FILL	
SINK HOLE, POTHOLE, ETC.	

ASBESTOS CEMENT PIPE	ACP
CAST IRON PIPE	CIP
CELLAR	C
CONCRETE SEWER PIPE-EXTRA STRENGTH	CSPX
CORRUGATED METAL PIPE	CMP
ELLIPTICAL REINFORCED CONCRETE PIPE	ERCP
EXCAVATION	EXC.
FIRST FLOOR	FF
FOOTING	FT
POLYVINYL CHLORIDE PIPE	PVC
REINFORCED CONCRETE PIPE (ALL CLASSES)	RCP
RIGHT-OF-WAY	R/W
TERRA COTTA	TC
VITRIFIED CLAY PIPE-STD STRENGTH	VCP
VITRIFIED CLAY PIPE-EXTRA STRENGTH	VCPX
WROUGHT IRON PIPE	WIP

EXISTING WORK

	SIZE & SD NUMBER
STORM DRAIN	
STORM DRAIN INLETS	
STORM DRAIN MANHOLES (SD)	
SEWERS	
SEWER TERMINAL MANHOLE	
RECTANGULAR SEWER MANHOLE	
SEWER MANHOLE	
LAMPHOLE	
WATER MAIN	
WATER MANHOLE	
VALVE	
VALVE (AIR)	
TEE	
CROSS	
RIP-RAP	
REDUCER	
BEND	
BLOW-OFF	
FIRE HYDRANT	
METER BOX	
ELEVATED WATER TANK	
PIPE CROWN	
PIPE INVERT	



DEPARTMENT OF ENVIRONMENTAL RESOURCES

APPROVED BY: *Stan E. Wildesen* DATE: *9/16/01*
 Stan E. Wildesen, P.E.
 Assoc. Director











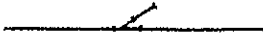
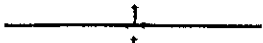

REVISION

JAN. 2001

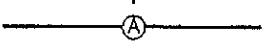
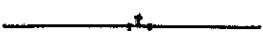
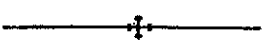
STORM DRAIN
CONVENTIONAL
SYMBOLS

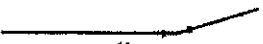
SD
1.0

PROPOSED WORK

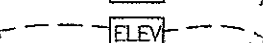
STORM DRAIN	
STORM DRAIN INLETS	
STORM DRAIN MANHOLES (SD)	
SEWER	
SEWER LAMPHOLE	
Y BRANCH (Y BR)	
HOUSE CONNECTION (HC)	
DROP HOUSE CONNECTION (DHC)	
WATER MAIN VALVE (V)	
VALVE (AIR)	
TEE (T)	
CROSS (C)	
REDUCER (R)	
BEND (B)	
BLOW-OFF	
FIRE HYDRANT (FH)	
PROPOSED CONTOUR	
EXISTING CONTOUR	



DEPARTMENT OF
ENVIRONMENTAL RESOURCES

APPROVED BY:
Stan E. Wildesen
Stan E. Wildesen, P.E.
Assoc. Director

DATE:
3/16/01

REVISION

JAN. 2001

STORM DRAIN
CONVENTIONAL
SYMBOLS

SD
1.1

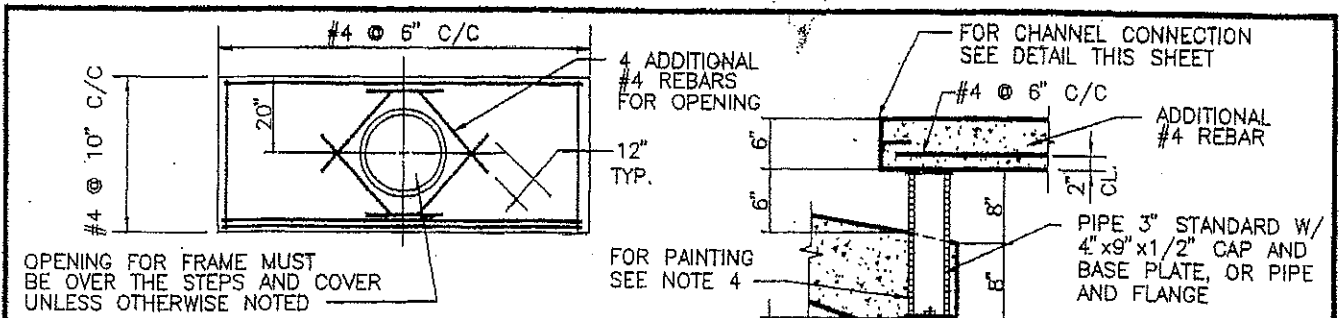

OPENING FOR FRAME MUST BE OVER THE STEPS AND COVER UNLESS OTHERWISE NOTED

FOR PAINTING SEE NOTE 4

PLAN- TOP SLAB

SECTION THRU PIPE SUPPORT

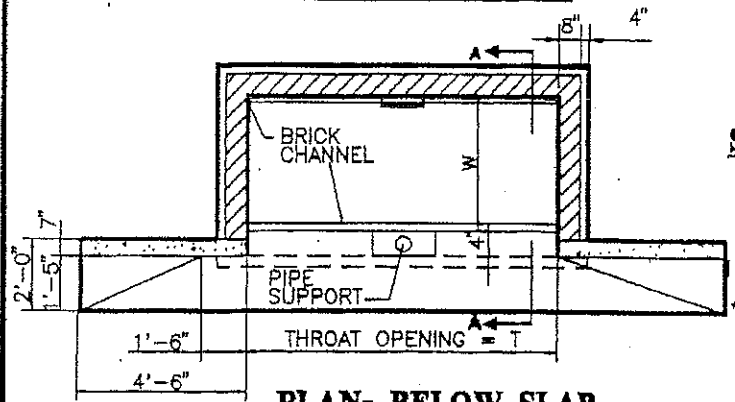

PLAN- BELOW SLAB

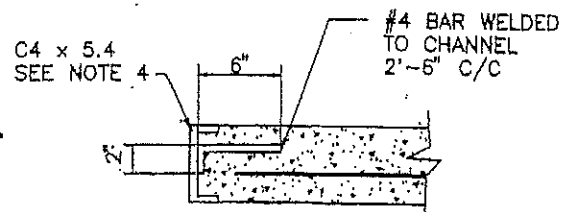

CHANNEL DETAIL

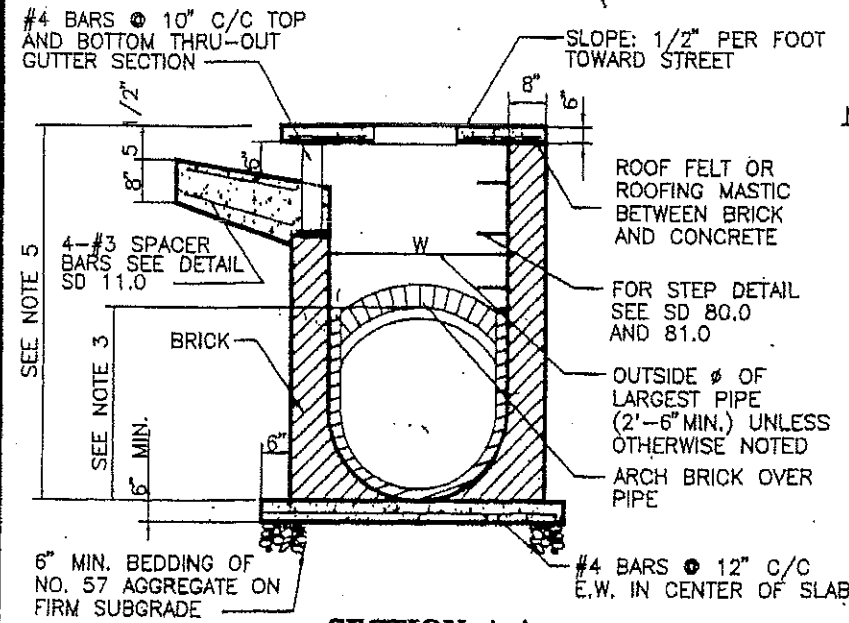

SECTION A-A

NOTES:

1. fc' = 4,000 psi @ 28 DAYS WITH AIR ENTRAINED.
2. ALL REINFORCING STEEL TO BE ASTM A615 GRADE 60.
3. CHANNEL TO BE BUILT TO CROWN OF PIPE.
4. APPLY ONE SHOP COAT AND ONE FIELD COAT OF APPROVED BATTLESHIP GRAY PAINT IN ACCORDANCE WITH PRINCE GEORGE'S COUNTY STANDARD SPECIFICATIONS.
5. SPECIAL DESIGN IS REQUIRED FOR STRUCTURES DEEPER THAN 8' AND SPECIAL DESIGN IS REQUIRED FOR TOP SLAB THAT EXCEEDS MAXIMUM WIDTH REQUIREMENTS.
6. PROVIDE "CHESAPEAKE BAY DRAINAGE DON'T DUMP" ON FRONT FACE OF TOP SLAB. (SD. 82.0)
7. PIPES CAN NOT BE USED AS STEPS.
8. FOR PIPES 30" OR LARGER PROVIDE STEPS IN CHANNELS OF STRUCTURES, SEE SD 110.0.
9. ON TERMINAL INLETS, THE BOTTOM SHALL BE SLOPED TO OUTLET PIPE WITH 9" MINIMUM FALL.

DESIGNATION	BOTTOM SLAB THICKNESS	T-THROAT OPENING	NUMBER * OF PIPE SUPPORTS	MAXIMUM WIDTH (W)	MINIMUM WIDTH (W)
A - 5	6"	5'-0"	0	5'	2'-6"
A - 10	6"	10'-0"	1	10'	2'-6"
A - 15	8"	15'-0"	2	15'	2'-6"
A - 20	8"	20'-0"	3	20'	2'-6"

* PIPE SUPPORTS TO BE SPACED 5'-0" ON CENTER,

	DEPARTMENT OF ENVIRONMENTAL RESOURCES APPROVED BY: <i>Stan E. Wilden</i> Stan E. Wilden, P.E. Assoc. Director	DATE: 3/16/01	REVISION JAN, 2001	STORM DRAIN TYPE "A" INLET	SD 10.0

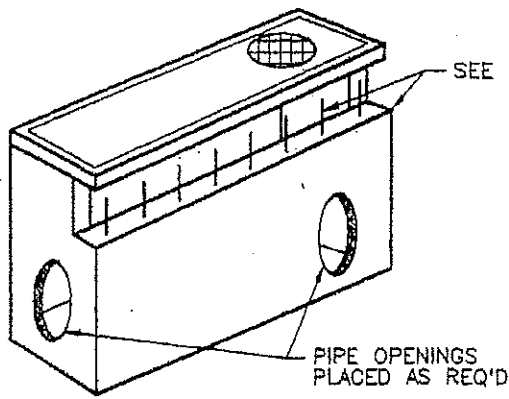

ISOMETRIC VIEW

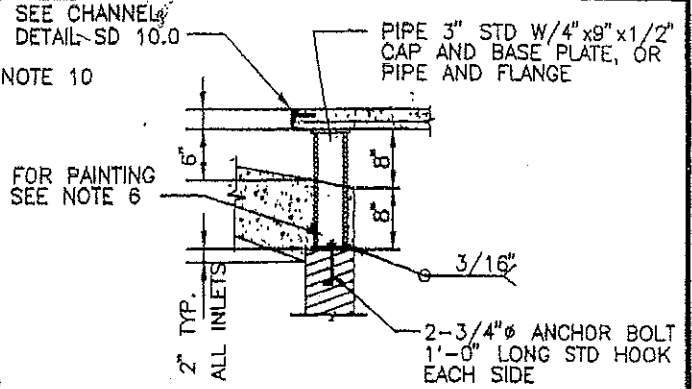

SECTION THRU PIPE SUPPORT

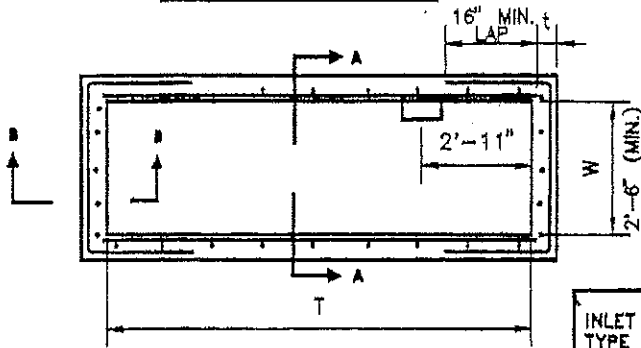

PLAN WITH SLAB REMOVED

MAX. 2 COURSES
BRICK & MORTAR
GRADE ADJUSTMENT

FOR TOP SLAB
DETAIL SEE
SD 10.0

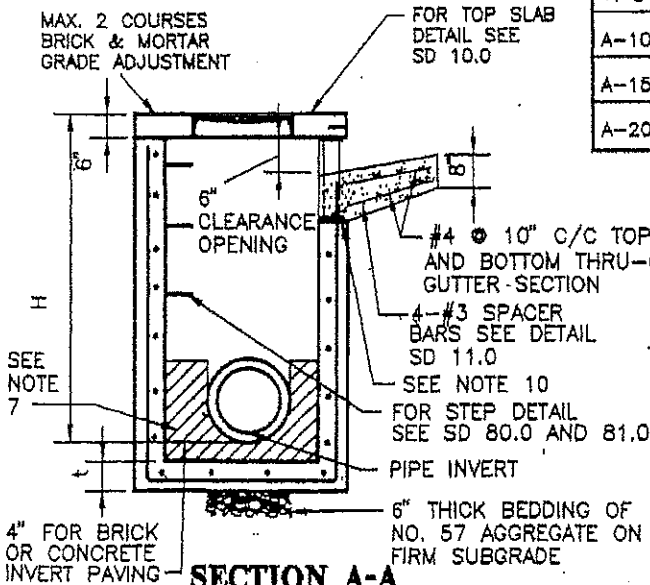

SECTION A-A

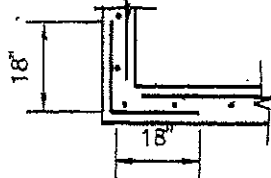

SECTION B-B

INLET TYPE	WALL (t) THICKNESS	MAXIMUM WIDTH (W)***	T	H	REINFORCEMENT	NUMBER # OF PIPE SUPPORTS
A-5	6"	5'	5'	8'	#4 ϕ 12" E.W.	0
A-10	6"	5'	10'	8'	#4 ϕ 6" E.W.	1
A-15	8"	7.5'	15'	12'	#4 ϕ 6" E.W.	2
A-20	8"	10'	20'	12'	#5 ϕ 6" E.W. (2 LAYERS)	3

*PIPE SUPPORTS TO BE SPACED 5'-0" ON CENTER
**RATIO MORE THAN 2:1 SHOULD BE DESIGNED AS A T-BEAM OR AS A TWO WAY SLAB.

NOTES:

1. CONCRETE STRENGTH SHALL BE $f_c' = 5,000$ psi ϕ 28 DAYS WITH AIR ENTRAINED. ALL REINFORCING STEEL TO BE ASTM A615 GRADE 60.
2. MINIMUM PIPE OPENING SHOULD BE PIPE OUTSIDE DIAMETER + 6".
3. 2" MINIMUM CONCRETE COVER REQUIRED.
4. PROVIDE "CHESAPEAKE BAY DRAINAGE DON'T DUMP" ON FRONT FACE OF TOP SLAB. (SD 82.0)
5. SHOP DRAWING APPROVAL IS REQUIRED IF DIFFERENT FROM THE STANDARD DETAIL.
6. PROVIDE BATTLESHIP GRAY PAINT FOR SUPPORT PIPES.
7. PROVIDE CONCRETE OR BRICK BENCH TO CROWN OF PIPE.
8. ACCESS OPENING MUST BE ABOVE STEPS.
9. PIPE CAN NOT BE USED AS STEPS.
10. PRECAST MANUFACTURER MAY PROVIDE PRODUCT UP TO TOE OF GUTTER SECTION. VERTICAL REBAR ON THE FRONT FACE SHOULD EXTEND 12".



DEPARTMENT OF
ENVIRONMENTAL RESOURCES

APPROVED BY:

Stan E. Wildesen

DATE:

3/14/01

Stan E. Wildesen, P.E.
Assoc. Director

REVISION

JAN. 2001

STORM DRAIN
TYPE "A"
PRECAST INLET

SD
10.1

WHERE STORM DRAINS RUN THRU INLETS, THE INLET SHALL BE BRICK LINED CHANNEL AS SHOWN FOR MANHOLES. ON TERMINAL INLETS, THE INLET BOTTOM SHALL BE SLOPED TO OUTLET PIPE WITH A 9° MIN. FALL.

SEE FRAME AND COVER SD 90.0
SLOPE: 1/2" = 12"
SEE CHANNEL DETAIL SD 10.0
VARIES SEE NOTE 8

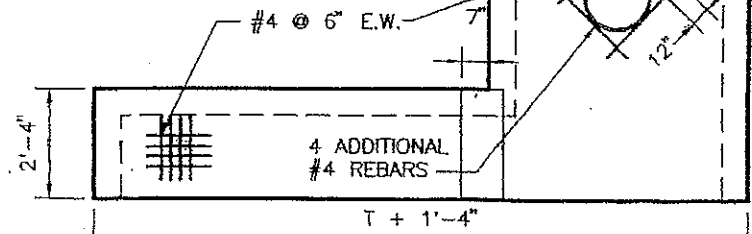

PLAN - TOP SLAB

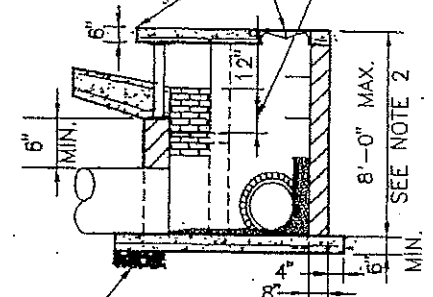

SECTION B-B

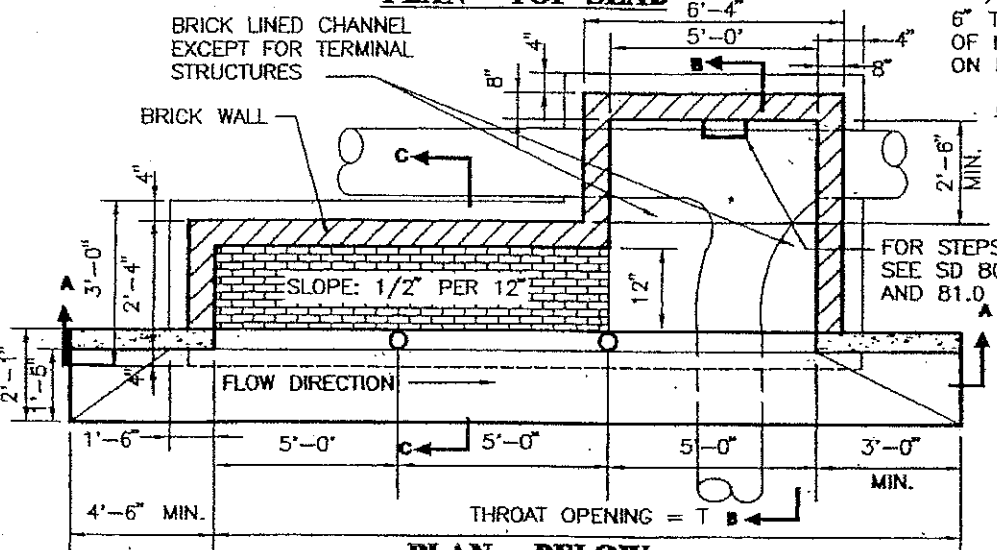

PLAN - BELOW

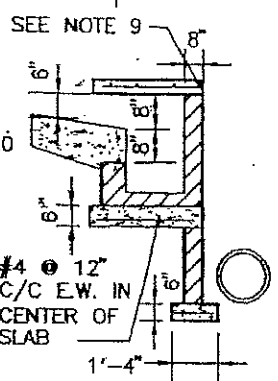

SECTION C-C

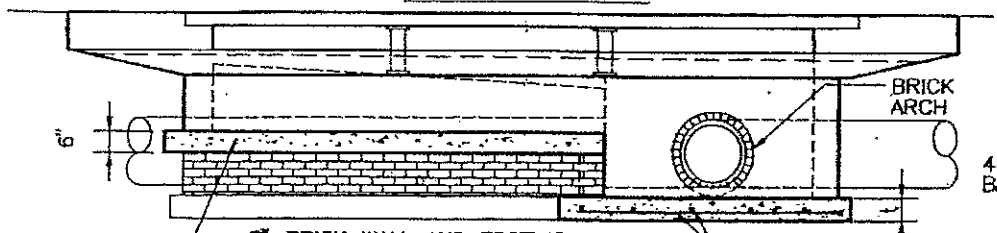

SECTION A-A
N.T.S.

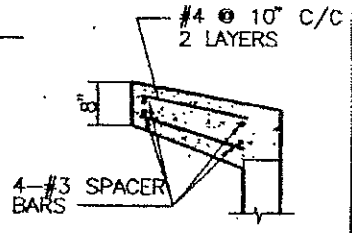

DETAIL

FOOTING WHERE PIPE IS NOT ADJACENT

8" BRICK WALL AND FOOTING IS REQUIRED UNDER INLET EXTENSION WHERE PIPE IS ADJACENT

NOTES: #4 @ 9" C/C E.W.

1. SEE PIPE SUPPORT DETAIL SD 10.0.
2. SPECIAL DESIGN IS REQUIRED FOR STRUCTURES DEEPER THAN 8".
3. FOR 30" AND LARGER PIPE PROVIDE STEPS IN CHANNEL SEE SD 110.0.
4. 8" THICK BRICK WALL.
5. $f_c' = 4,000$ psi @ 28 DAYS WITH AIR ENTRAINED.
6. ALL REINFORCING STEEL TO BE ASTM A615 GRADE 60.
7. PROVIDE "CHESAPEAKE BAY DRAINAGE DON'T DUMP" ON FRONT FACE OF TOP SLAB. (SD 82.0)
8. 12" MIN., 3'-0" MAX. AT UPSTREAM END OF CHANNEL.
9. PROVIDE ROOFING FELT OR ROOFING MASTIC BETWEEN BRICK AND CONCRETE.
10. PROVIDE BENCH UP TO CROWN OF PIPE.
11. ACCESS OPENING MUST BE ABOVE STEPS.
12. PIPE CAN NOT BE USED AS STEPS.

DESIGNATION	BOTTOM SLAB THICKNESS (t)	T-THROAT OPENING	NUMBER * OF PIPE SUPPORTS
B - 10	6"	10'-0"	1
B - 15	8"	15'-0"	2
B - 20	8"	20'-0"	3

*PIPE SUPPORTS TO BE SPACED 5'-0" ON CENTER.



DEPARTMENT OF ENVIRONMENTAL RESOURCES
APPROVED BY: *Stan E. Wildesen*
DATE: 3/16/01
Stan E. Wildesen, P.E.
Assoc. Director

REVISION
JAN. 2001

STORM DRAIN
TYPE "B"
INLET

SD
11.0

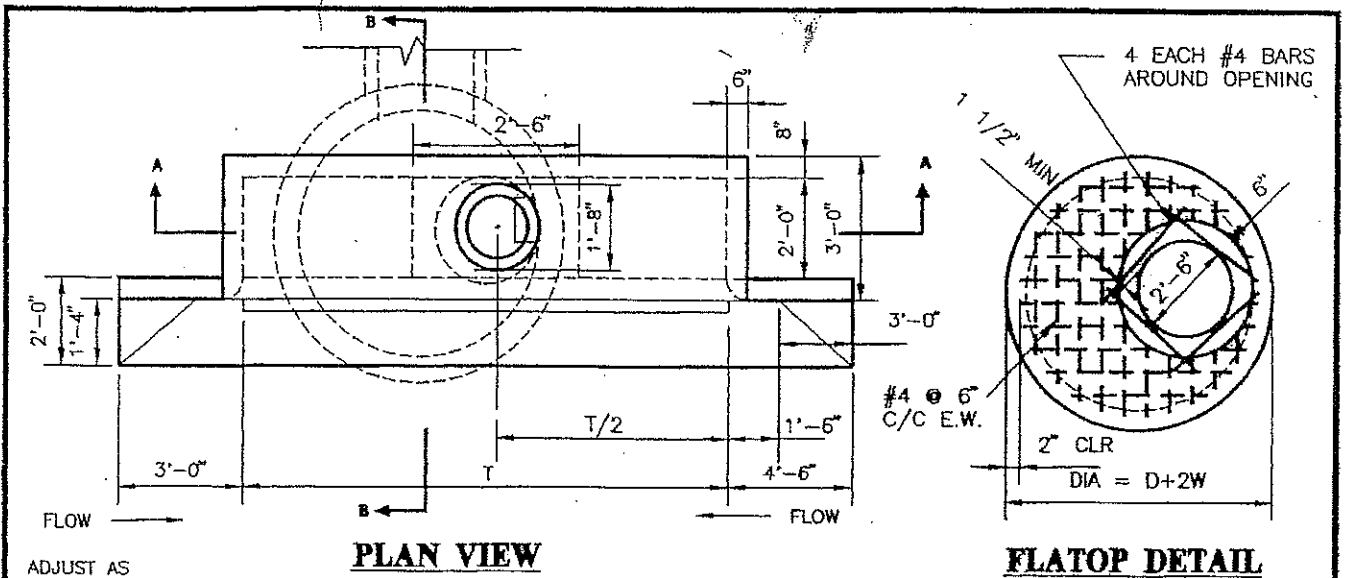

ADJUST AS NECESSARY SEE NOTE 3 SD 12.2

ALL STEPS SHALL CONFORM TO SD 80.0 & 81.0

W SEE NOTE 4

REINFORCEMENT SHALL BE EITHER WELDED WIRE FABRIC OR DEFORMED BARS AND CONFORM TO "R" IN CHART

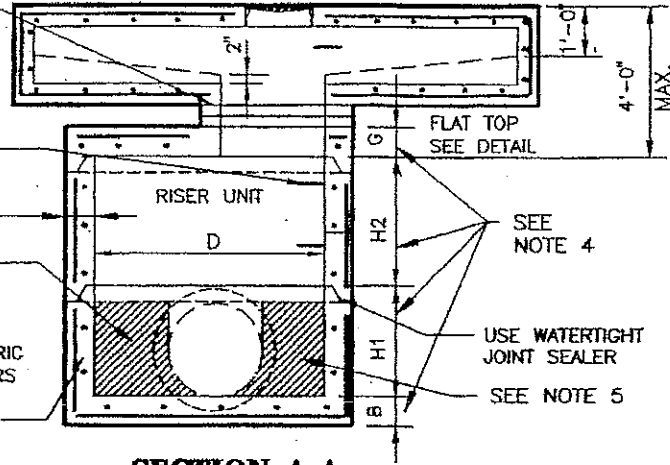

SECTION A-A

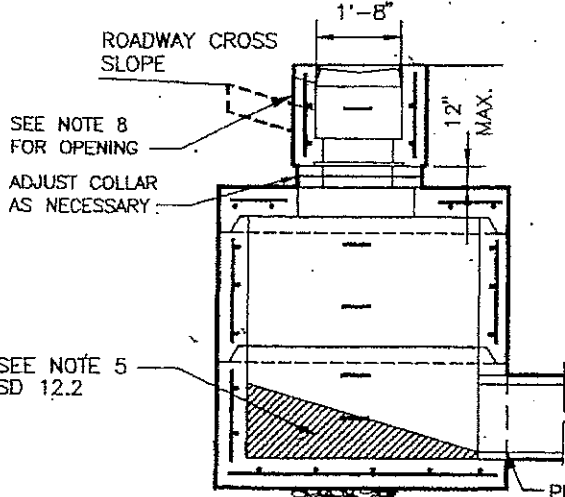

6" THICK BEDDING OF NO. 57 AGGREGATE ON FIRM SUBGRADE

SECTION B-B

NOTES:

1. CONCRETE STRENGTH SHALL BE $f_c' = 5,000$ psi @ 28 DAYS WITH AIR ENTRAINMENT.
2. ALL REINFORCEMENT STEEL TO BE ASTM A615, GRADE 60.
3. ACCESS OPENING TO BE OVER STEP.
4. FOR H1, H2, B, G, W RELATED TO BASE HEIGHT, RISER UNIT HEIGHT, BASE SLAB THICKNESS, WALL THICKNESS, REFER TO A TABLE ON SD 12.2.
5. PROVIDE BENCH UP TO CROWN OF PIPE.
6. PROVIDE "CHESAPEAKE BAY DRAINAGE, DON'T DUMP" ON FRONT OF TOP SLAB.
7. FOR REINFORCEMENT OF TROUGH AND WALLS, REFER TO A TABLE ON SD 12.2.
8. 6" THROAT OPENING AT FRONT FACE OF THE TOP SLAB.



DEPARTMENT OF ENVIRONMENTAL RESOURCES
 APPROVED BY: *Stan E. Wildesen*
 Stan E. Wildesen, P.E.
 Assoc. Director
 DATE: 3/16/01

REVISION	
JAN. 2001	

**STORM DRAIN
 TYPE "B"
 PRECAST INLET**

**SD
 12.0**

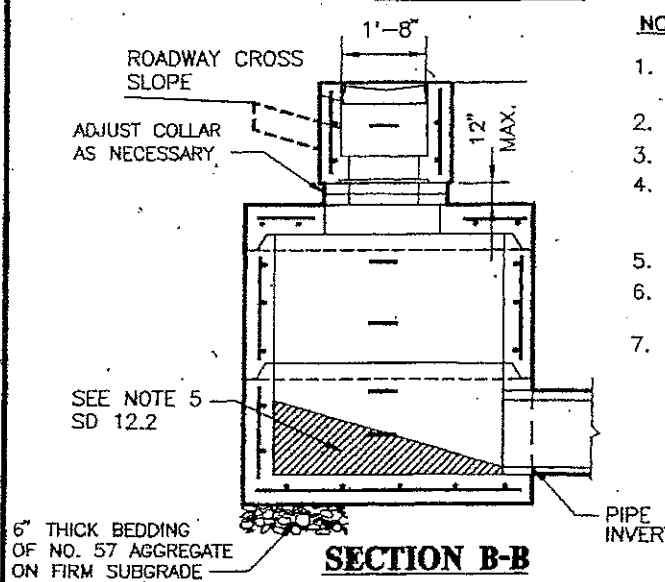
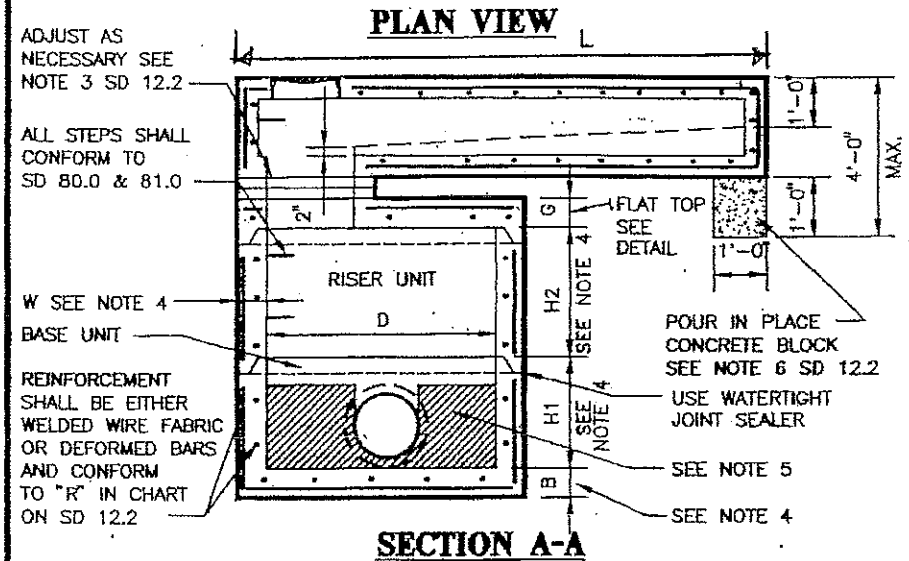
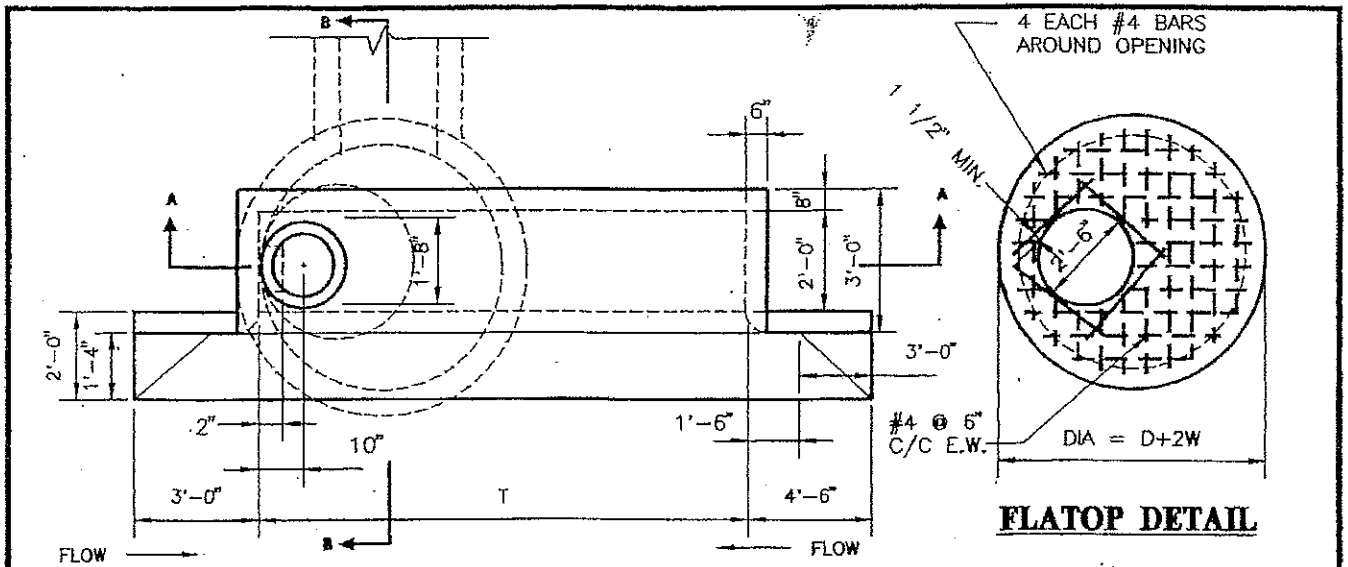

- NOTES:**
1. CONCRETE STRENGTH SHALL BE $f_c' = 5,000$ psi @ 28 DAYS WITH AIR ENTRAINED.
 2. ALL REINFORCEMENT STEEL TO BE ASTM A615, GRADE 60.
 3. ACCESS OPENING TO BE OVER STEP.
 4. FOR H1, H2, B, G, W RELATED TO BASE HEIGHT, RISER UNIT HEIGHT, BASE SLAB THICKNESS, WALL THICKNESS, REFER TO A TABLE ON SD 12.2.
 5. PROVIDE BENCH UP TO CROWN OF PIPE.
 6. PROVIDE "CHESAPEAKE BAY DRAINAGE, DON'T DUMP" ON FRONT OF TOP SLAB.
 7. FOR REINFORCEMENT OF TROUGH AND WALLS, REFER TO A TABLE ON SD 12.2.

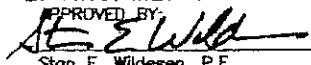
	DEPARTMENT OF ENVIRONMENTAL RESOURCES APPROVED BY:  Stan E. Wildesen, P.E. Assoc. Director	DATE: 3/16/01	REVISION JAN. 2001	STORM DRAIN TYPE "B" PRECAST INLET	SD 12.1

INLET TYPE	T	L	NUM. OF PIPE SUPPORTS *
B-5	5'-0"	6'-0"	0
B-10	10'-0"	11'-0"	1
B-15	15'-0"	16'-0"	2
B-20	20'-0"	21'-0"	3

*PIPE SUPPORT SHALL BE PLACED AT 5' INTERVALS

PIPE SIZE RANGE	CIRCULAR BASE AND RISER UNIT DIMENSIONS				FLAT TOP	AREA OF REINFORCEMENT (SQ. IN PER FT. FOR WALL)	BOTTOM SLAB	
							THICKNESS	AREA OF REINFORCEMENT (SQ. IN. PER FT.)
	H1	H2 *	W	D	G	R	B	
15" TO 24"	3' TO 5'	1' TO 5'	5"	48"	8"	0.12	8"	0.14
27" TO 36"	4' TO 6'	1' TO 6'	6"	60"	8"	0.15	8"	0.17
42" TO 48"	5' TO 7'	1' TO 7'	7"	72"	8"	0.18	8"	0.27
54" TO 66"	6' TO 8'	1' TO 8'	8"	84"	8"	0.21	8"	0.27
68" TO 72"	7' TO 8'	1' TO 8'	9"	96"	8"	0.24	8"	0.28
78" TO 84"	8' TO 9'	1' TO 8'	10"	108"	8"	0.27	8"	0.30

* IF THERE IS AN INCOMING PIPE IN A RISER UNIT, REFER TO H1 FOR HEIGHT LIMITATION

NOTES:

1. CURB OPENING SHALL NOT ENCR OACH UPON CROSSWALK AREAS.
2. ANGLES AND ANCHOR BOLTS TO BE GALVANIZED AFTER WELDING IN ACCORDANCE WITH ASTM A 123.
3. GRADE AND SLOPE ADJUSTMENT SHALL BE PROVIDED IN THE FIELD USING PRECAST ADJUSTMENT COLLAR RINGS WITH KEY. THE HEIGHT OF ADJUSTMENT IS 12" MAX.
4. A CONCRETE OR BRICK CHANNEL SHALL BE PROVIDED IN THE FIELD SLOPED AT 2" PER FOOT TOWARD OUTLET AND BERM SHALL BE CONSTRUCTED UP TO HALF HEIGHT OF OUTGOING PIPE.
5. SLOPED TROUGH FLOOR TO BE CONSTRUCTED IN FIELD USING BRICK OR CONCRETE AND USED WHEN ROAD GRADE IS 1.5% OR LESS.
6. PROVIDE CONCRETE BLOCK WHEN CONCRETE INLET IS INSTALLED AT THE END OF THE TROUGH FOR 10', 15', AND 20' OPENING ONLY.
7. TROUGH FRONT CAN BE CAST IN PLACE MONOLITHICALLY WITH ROAD GUTTER.
8. CONCRETE STRENGTH SHALL BE $f_c' = 5000$ psi @ 28 DAYS WITH AIR ENTRAINED. REINFORCEMENT STEEL TO BE ASTM A615 GRADE 60.
9. PROVIDE KEY ON EACH UNIT.
10. PROVIDE "CHESAPEAKE BAY DRAINAGE-DON'T DUMP" NOTE ON FRONT OF TOP SLAB. (SD 82.0)



DEPARTMENT OF ENVIRONMENTAL RESOURCES

APPROVED BY: *St. E. Wildesen* DATE: 3/16/01
 Stan E. Wildesen, P.E.
 Assoc. Director

REVISION

JAN. 2001

STORM DRAIN
 TYPE "B"
 PRECAST INLET

SD
 12.2

INLET OPENING TO BE LOCATED AS REQUIRED, CENTER, LEFT OR RIGHT

SEE END WALL DETAIL THIS SHEET

SEE SD 90.0 FRAME AND COVER

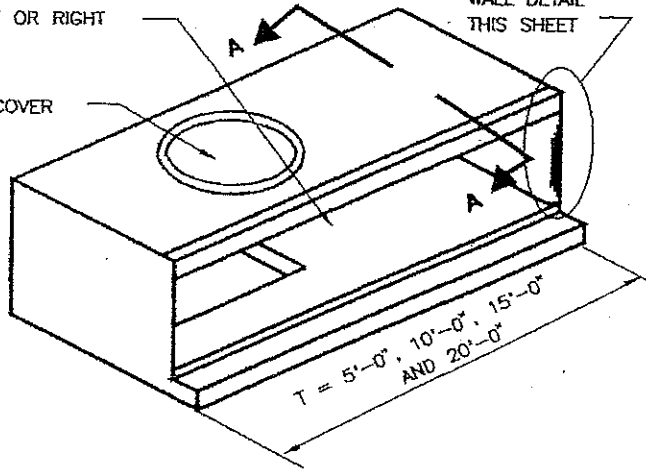

ISOMETRIC VIEW

N.T.S.

4"x3"x1/4" WITH 1/2"x4" SHEAR STUD CONNECTIONS @ 24" C/C GALV. AFTER WELDING SEE NOTE 5 SD 10.0 FOR PAINTING

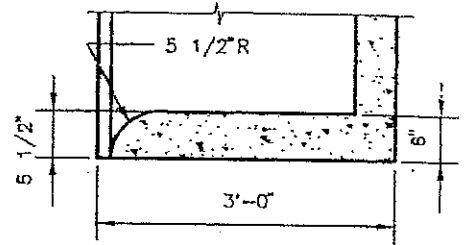

END WALL DETAIL

N.T.S.

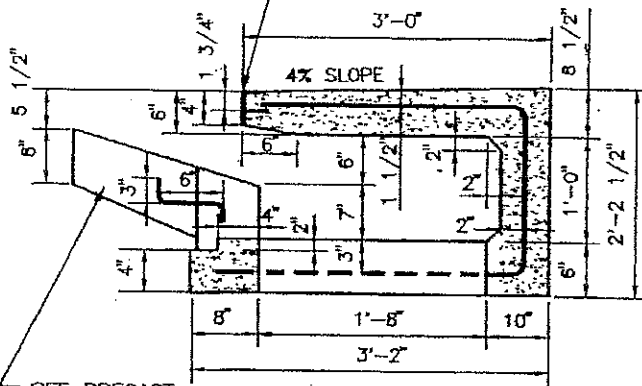

SECTION A-A

N.T.S.

SEE PRECAST TROUGH FRONT DETAIL THIS SHEET

HANDLING DEVICE IS #5 BARS PLACED 5' C/C

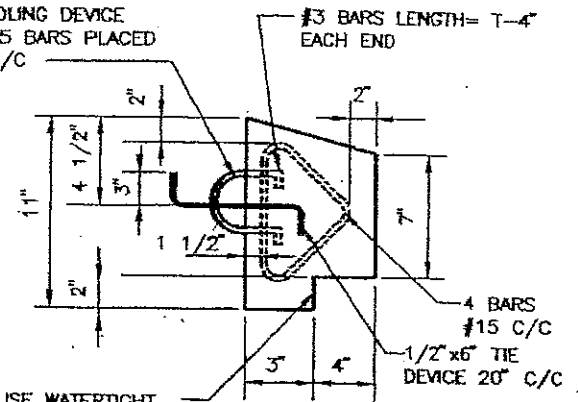

PRECAST TROUGH FRONT

N.T.S.

USE WATERTIGHT JOINT SEALER

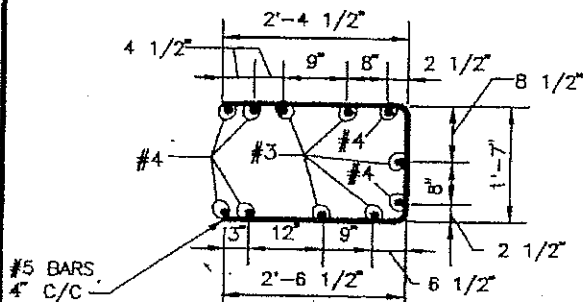

REINFORCEMENT DETAIL

N.T.S.

USE 4 ADDL #3 BARS AROUND FRAME AND COVER

NOTES:

1. $f_c' = 5,000 \text{ psi @ 28 DAYS WITH AIR ENTRAINED.}$
2. ALL REINFORCING STEEL TO BE ASTM A 615 GRADE .60.
3. 2" CLEARANCE BETWEEN CONCRETE AND REBARS.



DEPARTMENT OF ENVIRONMENTAL RESOURCES

APPROVED BY:

Stan E. Wildesen
Stan E. Wildesen, P.E.
Assoc. Director

DATE:

3/16/01

REVISION

JAN. 2001

STORM DRAIN TYPE "B" PRECAST INLET TROUGH

SD 12.3

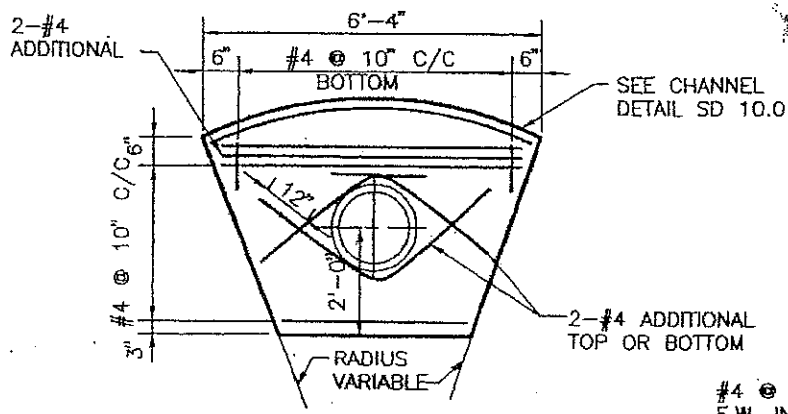

PLAN - TOP SLAB

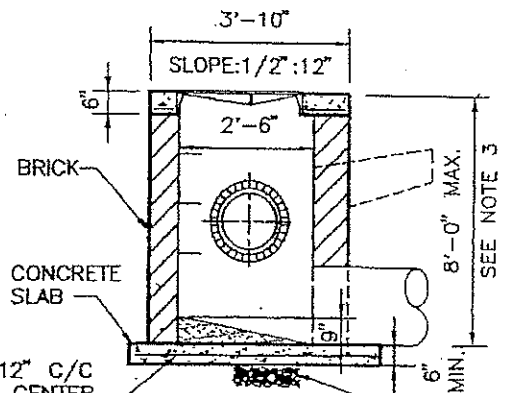

TYPE "C-I-P" INLET

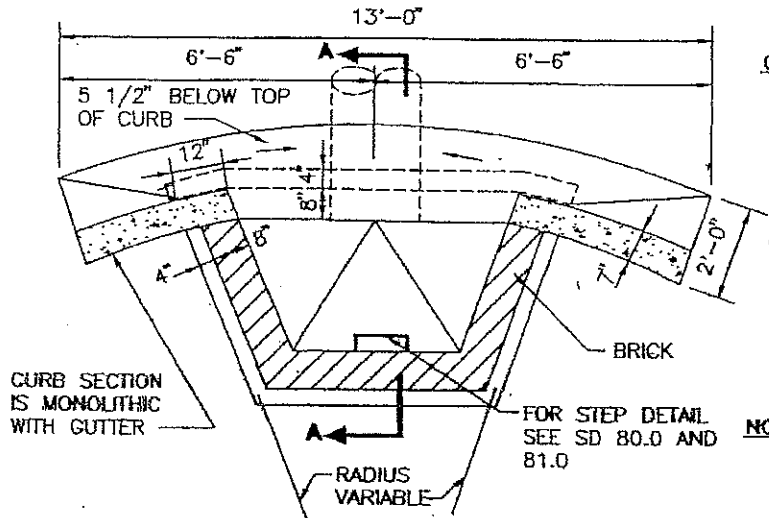

PLAN - BELOW

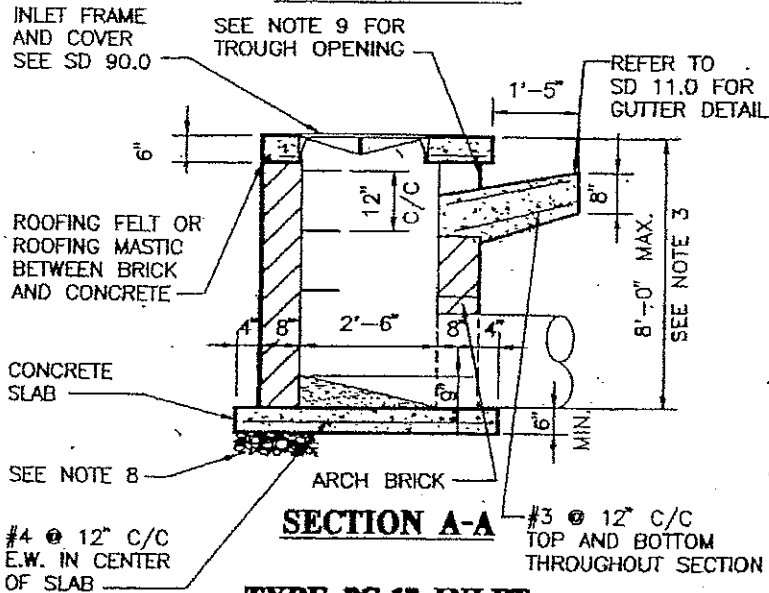

TYPE "C-I" INLET

C-I-P NOTES:

- A. C-I-P SAME AS C-I INLET, WITH CURB AND GUTTER ELIMINATED AND INLET PIPE ADDED.
- B. PARGING IS REQUIRED FOR BRICK CONSTRUCTION IN ACCORDANCE WITH PRINCE GEORGE'S COUNTY STANDARD SPECIFICATIONS
- C. GRADES GIVEN FOR TOPS OF INLETS REFER TO FRONT EDGE OF SLAB AT CENTER OF INLET. SLABS SHALL BE SET TO CONFORM TO SHAPE OF STREET OR CURB. TYPICAL FOR C-I AND C-I-P INLETS.

NOTES:

- 1. $f_c' = 4,000$ psi @ 28 DAYS WITH AIR ENTRAINED.
- 2. ALL REINFORCING STEEL TO BE ASTM A615 GRADE 60.
- 3. 8" BRICK WALLS ARE STRUCTURALLY SATISFACTORY TO A DEPTH OF 8'-0".
- 4. FOR PIPES 30" AND LARGER, PROVIDE STEPS IN CHANNELS OF STRUCTURES, SEE SD 110.0.
- 5. WHERE STORM DRAINS RUN THRU INLETS, THE INLET SHALL BE FORMED WITH BRICK LINED CHANNEL AS SHOWN FOR MANHOLES. ("A" MANHOLE)
- 6. SPECIAL DESIGN IS REQUIRED FOR STRUCTURES DEEPER THAN 8' AND SPECIAL DESIGN IS REQUIRED FOR TOP SLAB WITH WIDTH GREATER THAN 3'.
- 7. PROVIDE "CHESAPEAKE BAY DRAINAGE DON'T DUMP" ON FRONT FACE OF TOP SLAB. (SD 82.0)
- 8. PROVIDE 6" THICK BEDDING OF NO. 57 AGGREGATE ON FIRM SUBGRADE.
- 9. 6" THROAT OPENING AT THE FRONT FACE OF THE TOP SLAB.



DEPARTMENT OF ENVIRONMENTAL RESOURCES
 APPROVED BY: *Ston E. Wildesen*
 Ston E. Wildesen, P.E.
 Assoc. Director

DATE: 3/16/01

REVISION
JAN. 2001

STORM DRAIN
 TYPE "C-I" AND "C-I-P"
 INLETS

SD
 13.0

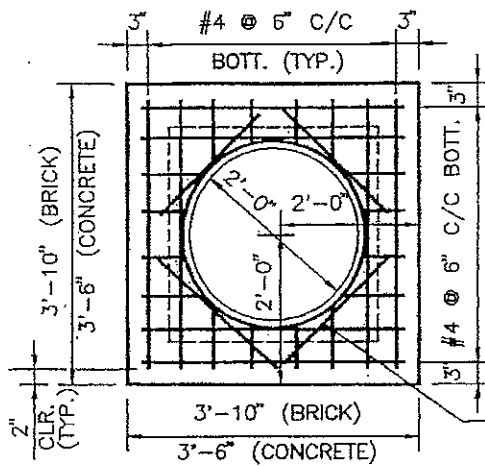

PLAN OF TOP SLAB "D1" INLET

STANDARD WR SINGLE FRAME AND GRATE SEE DETAIL SD 14.1

4 ADDITIONAL #4 BARS AROUND OPENING

SEE DETAIL SD 14.1 FOR SECTIONS C-C AND D-D

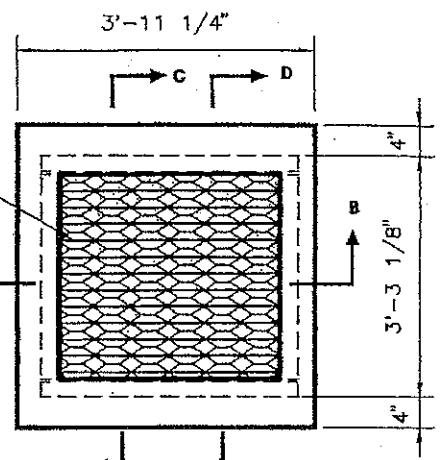

PLAN OF TOP SLAB "D2" INLET

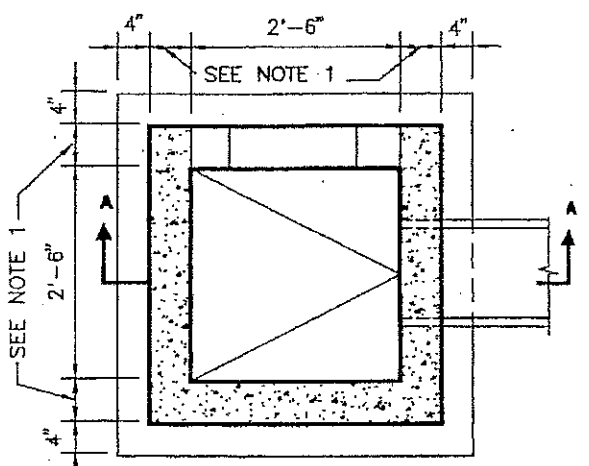

PLAN WITH TOP SLAB REMOVED

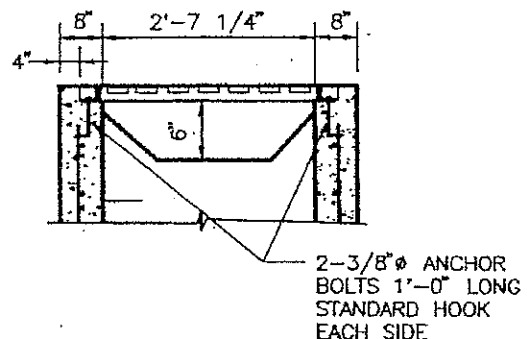

SECTION B-B - "D2" INLET

FOR BASE DETAIL SEE "D1" INLET

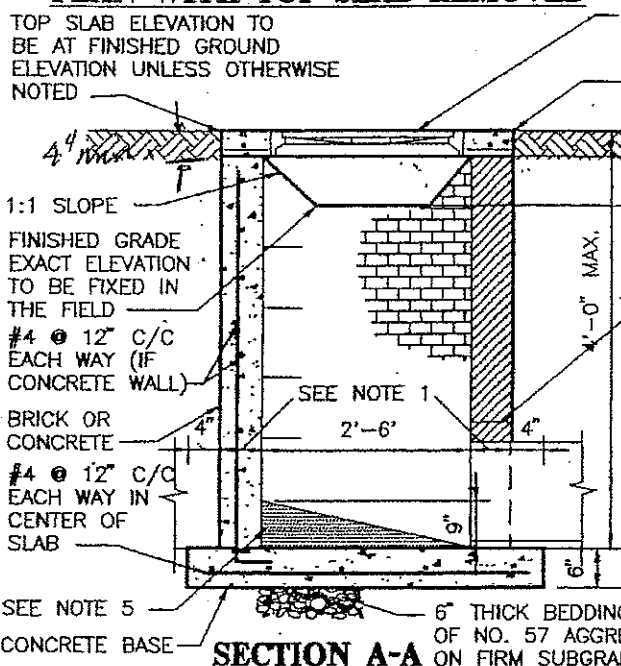

SECTION A-A

INLET FRAME AND COVER SEE SD 90.0
POINT AT WHICH TOP GRADE IS GIVEN

6" UNLESS OTHERWISE SPECIFIED. PLACE #4 BARS x 3'-4" LONG HORIZ. ACROSS LARGER OPENINGS TO LIMIT CLEAR VERT. SPACE TO 6" MAX. OPENINGS MAY BE PLACED IN ANY OR ALL SIDES AS SPECIFIED.

ARCH BRICK AROUND PIPE

NOTES:

1. IF WALL IS BRICK, MIN. WALL THICKNESS IS 8". IF WALL IS CONCRETE MIN. IS 6".
2. STEEL GRATING BARS SHALL BE COATED IN ACCORDANCE WITH DEPARTMENT OF ENVIRONMENTAL RESOURCES SWM STANDARDS AND SPECIFICATIONS.
3. $f_c' = 4,000$ psi @ 28 DAYS WITH AIR ENTRAINED.
4. ALL REINFORCING STEEL TO BE ASTM A615 GRADE 60.
5. PROVIDE SLOPES (2" PER FOOT) AS SHOWN IF USED AS TERMINAL.
6. STEP MUST BE LOCATED UNDER ACCESS OPENING. REFER TO SD 80.0 AND 81.0 FOR STEP DETAILS.



DEPARTMENT OF ENVIRONMENTAL RESOURCES
APPROVED BY: *St. E. Wildesen*
St. E. Wildesen, P.E.
Assoc. Director

DATE: 3/16/01

REVISION
JAN. 2001

STORM DRAIN
TYPE "D1" AND "D2"
INLETS

SD
14.0

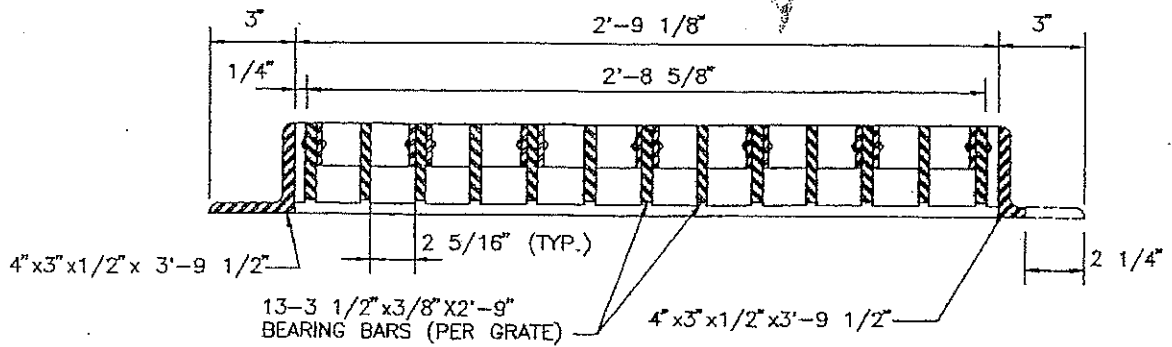

SECTION C-C

(FROM SD 14.0)

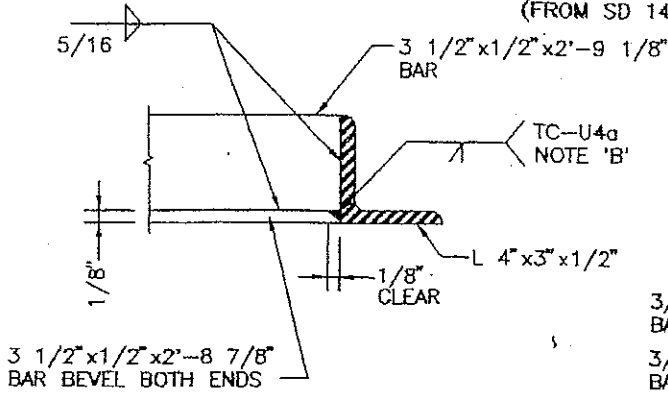

NOTE 'B'

WELD 3 1/2\"/>

WELD DETAIL

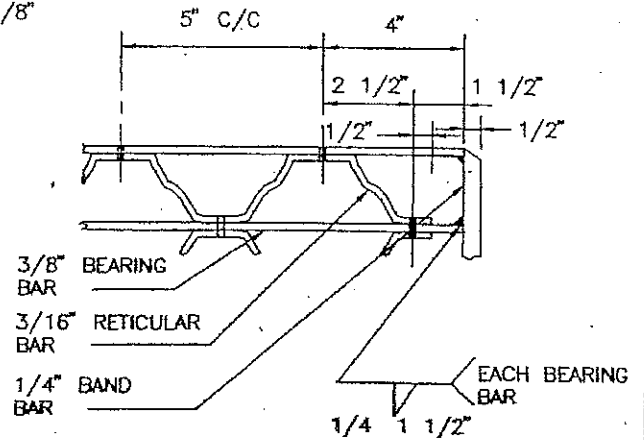

GRATING DETAIL

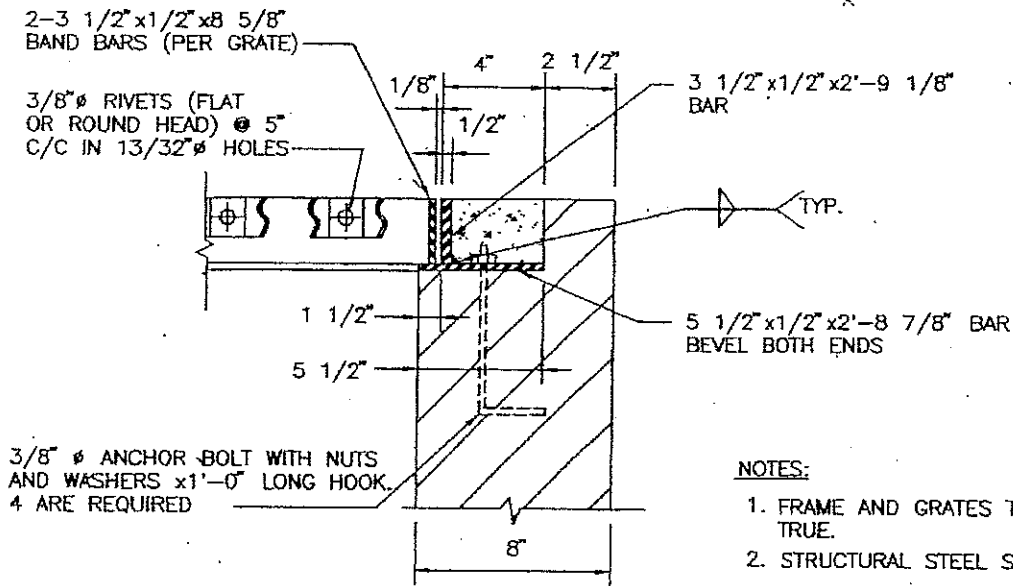

SECTION D-D

(FROM SD 14.0)

NOTES:

1. FRAME AND GRATES TO BE SQUARE, FLAT AND TRUE.
2. STRUCTURAL STEEL SHALL BE ASTM A-36.
3. FRAME AND GRATE TO BE GALVANIZED AFTER FABRICATION IN ACCORDANCE WITH ASTM A-123 EXCEPT FOR ADHERENCE WHICH SHALL BE IN ACCORDANCE WITH ASTM A-153.



DEPARTMENT OF ENVIRONMENTAL RESOURCES

APPROVED BY: *Stan E. Wildesen*
 Stan E. Wildesen, P.E.
 Assoc. Director

DATE: 3/16/01

REVISION

JAN. 2001

**STORM DRAIN
 TYPE "D"
 INLET GRATE**

**SD
 14.1**

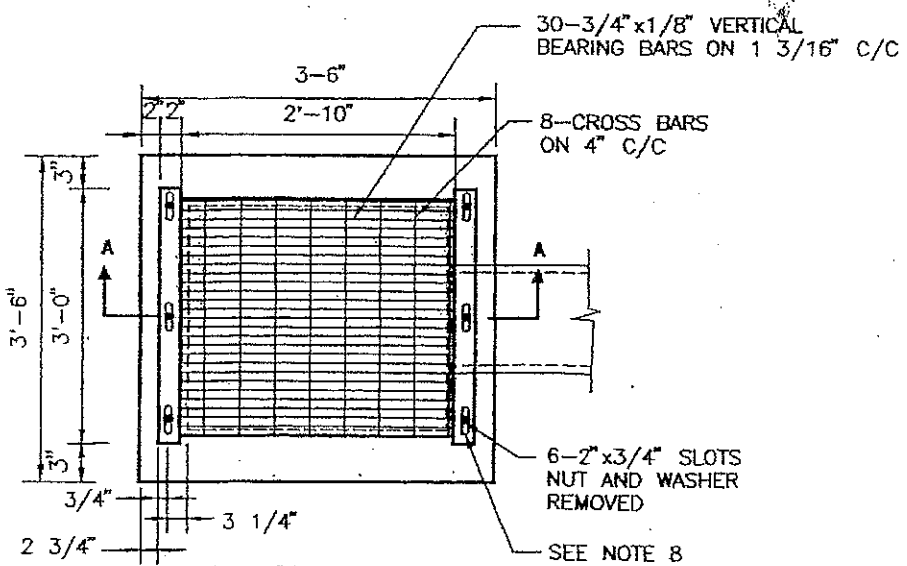

PLAN VIEW
N.T.S.

SEE CORNER
DETAIL THIS
SHEET

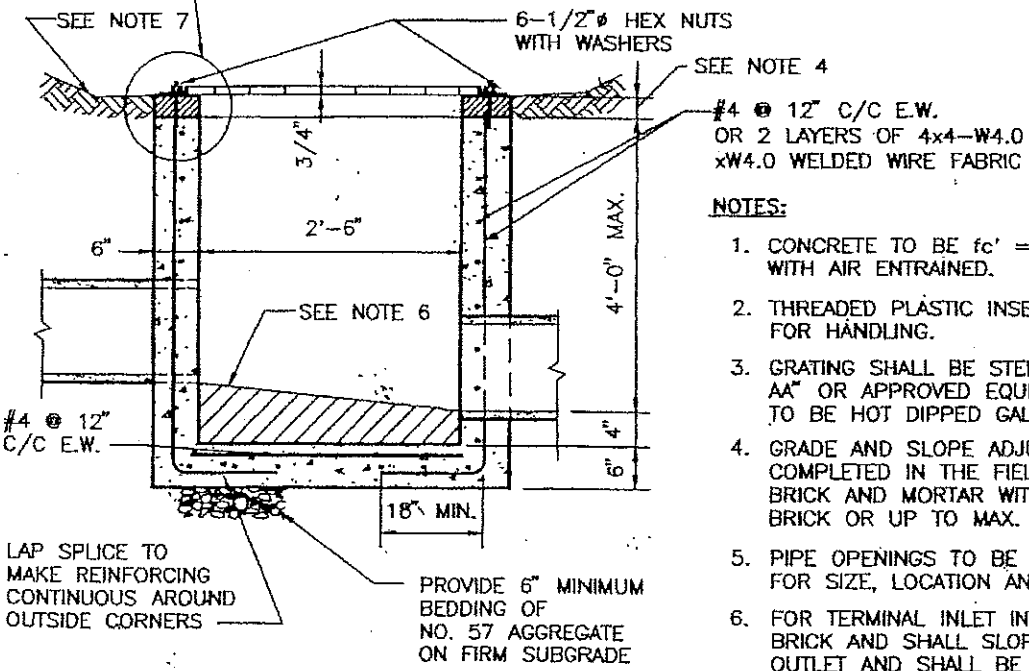

#4 @ 12" C/C E.W.
OR 2 LAYERS OF 4x4-W4.0
xW4.0 WELDED WIRE FABRIC

NOTES:

1. CONCRETE TO BE $f_c' = 5,000$ psi @ 28 DAYS WITH AIR ENTRAINMENT.
2. THREADED PLASTIC INSERTS TO BE PROVIDED FOR HANDLING.
3. GRATING SHALL BE STEEL IRVING X-BAR TYPE AA" OR APPROVED EQUIVALENT. ALL MATERIAL TO BE HOT DIPPED GALVANIZED.
4. GRADE AND SLOPE ADJUSTMENTS TO BE COMPLETED IN THE FIELD USING CONCRETE OR BRICK AND MORTAR WITH MIN. ONE COURSE OF BRICK OR UP TO MAX. 6" OF CONCRETE.
5. PIPE OPENINGS TO BE PROVIDED AS REQUIRED FOR SIZE, LOCATION AND INVERT ELEVATION.
6. FOR TERMINAL INLET INVERT TO BE CONCRETE OR BRICK AND SHALL SLOPE 2" PER FOOT TOWARD OUTLET AND SHALL BE PROVIDED IN THE FIELD.
7. SLOPE GROUND TOWARD INLET TO PROVIDE POSITIVE DRAINAGE.
8. 2-2" x 1 1/4" x 3/16" x 3' LONG (CENTERED ON GRATE) THEN TRIM VERTICAL LEG OF ANGLE TO 3/4". WELD SECURELY TO GRATING AT EVERY FOURTH BAR. TOUCH UP WELDED AREAS WITH ZINC-RICH PAINT AFTER WELDING.
9. MIN. 12" EARTH COVER OVER PIPE.
10. INSTALL STEPS IN ACCORDANCE WITH SD 81.0 AND 82.0.

SECTION A-A

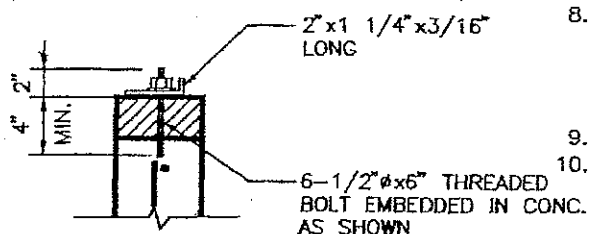

TYPICAL CORNER DETAIL



DEPARTMENT OF
ENVIRONMENTAL RESOURCES
APPROVED BY:
St. S. Wild
Ston E. Wildesen, P.E.
Assoc. Director

DATE:
3/16/01

REVISION
JAN. 2001

**STORM DRAIN
PRECAST
YARD INLET**

**SD
15.0**

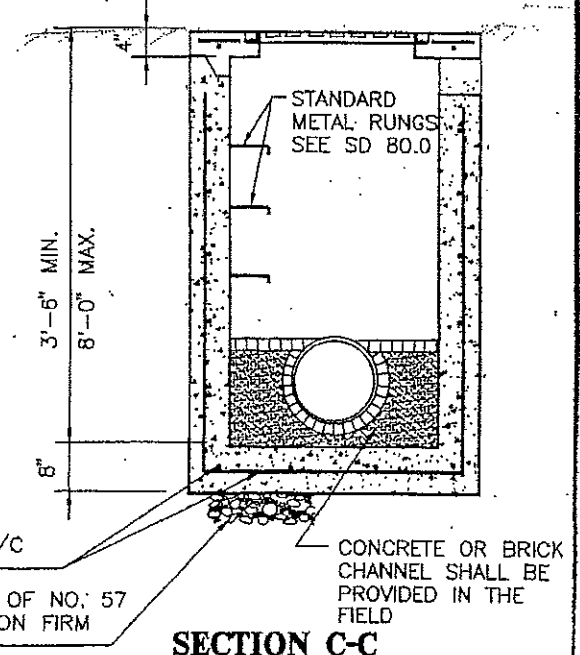
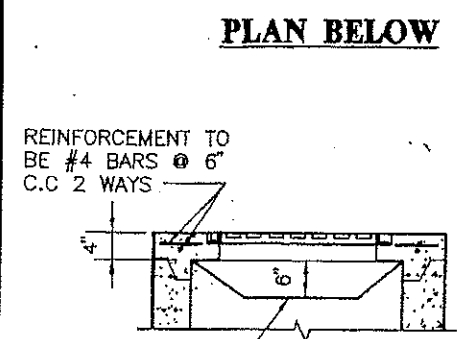
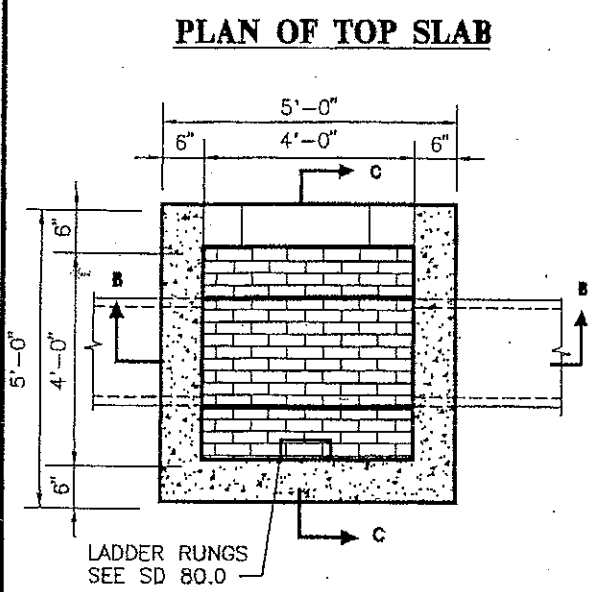
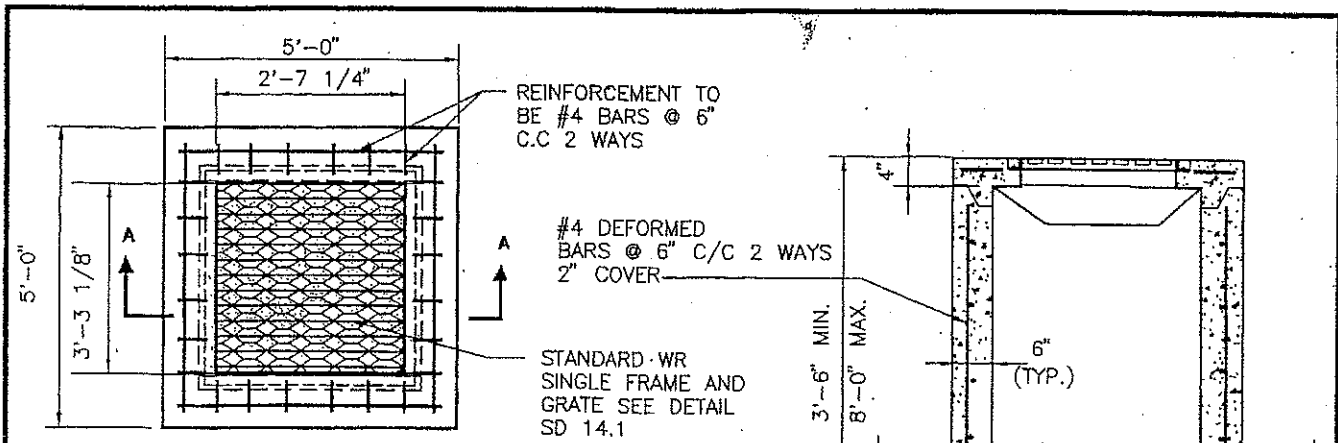

- NOTES:
1. THE CONSTRUCTION OF THE STRUCTURE MUST BE IN ACCORDANCE WITH PRINCE GEORGE'S COUNTY, DEPARTMENT OF ENVIRONMENTAL RESOURCES, STORMWATER STANDARDS AND SPECIFICATIONS.
 2. ALL REINFORCING STEEL TO BE ASTM A615 GRADE 60.
 3. PROVIDE 8 ADDITIONAL #4 BARS REINFORCEMENT FOR PIPE OPENINGS AND SLOTS.
 4. $f_c' = 5,000$ psi FOR PRECAST @ 28 DAYS WITH AIR ENTRAINED.
 5. FOR TRAFFIC AREA, TOP SLAB AND FRAME AND COVER MUST BEAR HS20 LOADING.

	DEPARTMENT OF ENVIRONMENTAL RESOURCES APPROVED BY: <i>Ston E. Wildesen</i> Ston E. Wildesen, P.E. Assoc. Director	REVISION JAN. 2001	STORM DRAIN TYPE "E" INLET	SD 16.0
	DATE: 3/16/01			

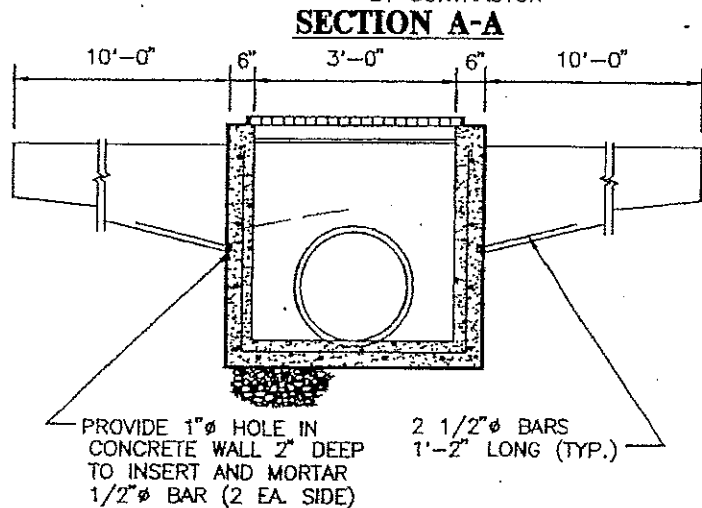
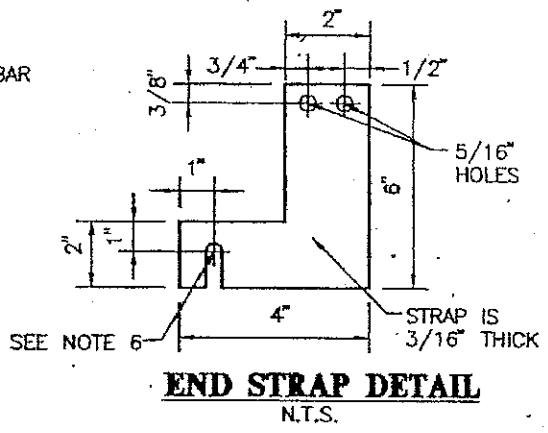
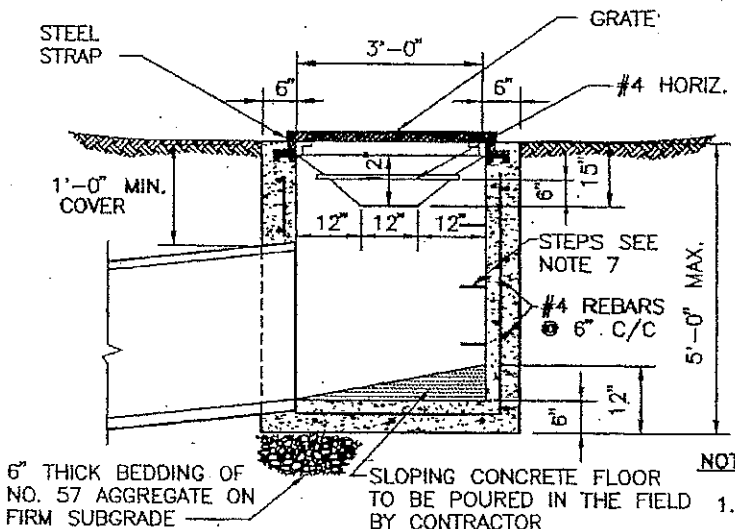
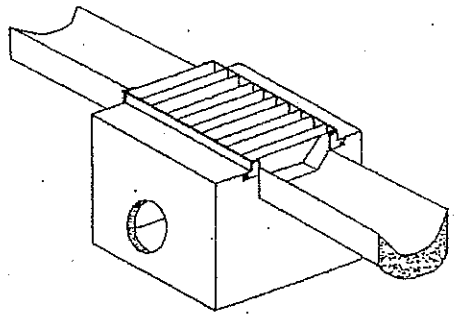
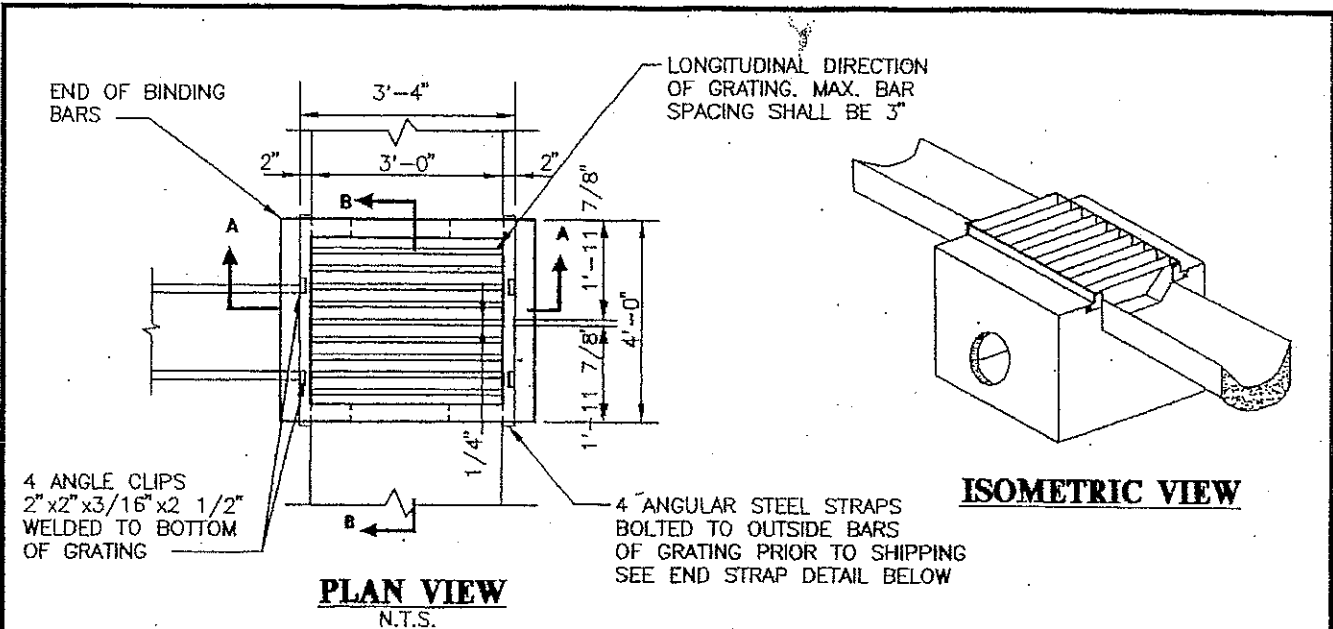

- NOTES:**
1. THE CONCRETE VALLEY GUTTER TO BE USED IN THE CONNECTION WITH THIS INLET SHALL BE TRANSITIONED TO MEET EXISTING DITCH OR PAVEMENT. THIS TRANSITION WILL TAKE PLACE WITHIN 10' OF THIS INLET. THE CONCRETE VALLEY IS TO BE 6" THICK WITH 6" x 6" - W2.1XW2.1 WIRE MESH PLACED AT CENTER OF CONCRETE.
 2. PIPE OUTLETS AND GUTTER APPROACHES CAN BE REVISED TO MEET EXISTING CONDITIONS.
 3. CONCRETE CONSTRUCTION TO BE $f_c' = 5,000$ psi @ 28 DAYS WITH AIR ENTRAINED. REINFORCEMENT #4 BARS AT 12" C/C 2" COVER.
 4. GRATING SHALL BE HOT DIPPED GALVANIZED AND SHALL WITHSTAND A LIVE LOAD OF 150 PSF.
 5. INSIDE WALLS MAY BE TAPERED 1/2".
 6. 9/16" SLOTTED HOLE TO RECEIVE 1/2" x 4" GALVANIZED MACHINE BOLT IMBEDDED 3" INTO CONCRETE WALL. NUT AND WASHER TO BE PLACED ON END OF BOLT AFTER GRATE IS INSTALLED.
 7. PROVIDE STEP AT 1'-4" C/C BELOW TOP OPENING REFER TO SD 80.0 AND 81.0 FOR STEP DETAIL.
 8. ALL REINFORCEMENT STEEL TO BE ASTM A615 GRADE 60.

<p>DEPARTMENT OF ENVIRONMENTAL RESOURCES</p> <p>APPROVED BY: <i>Stan E. Wildesen</i></p> <p>DATE: 3/16/01</p> <p>Stan E. Wildesen, P.E. Assoc. Director</p>	<p>REVISION</p> <p>JAN. 2001</p>	<p>STORM DRAIN TYPE "K" PRECAST INLET NON-TRAFFIC AREAS</p>	<p>SD 17.0</p>
	<p>3/16/01</p>		

STANDARD FRAME AND COVER SEE SD 90.0, 90.1 90.2, AND 90.3 SEE NOTE 8

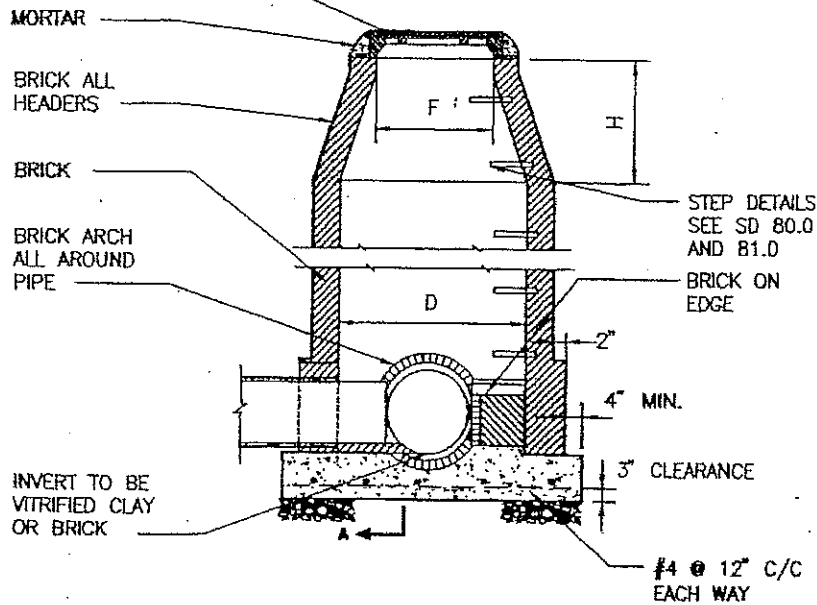

MANHOLE DIMENSIONS			
PIPE DIA.	D.	F (MIN.)	H (MIN.)
15" - 24"	4'-0"	24"	48"
27" - 36"	5'-0"	24"	52"
42" - 48"	6'-0"	24"	63"
54" - 60"	7'-0"	24"	84"

WALL & BASE SLAB SCHEDULE	
DEPTH	THICKNESS
TO 12'-0"	8"
12'-16'	12"

MANHOLE SECTION

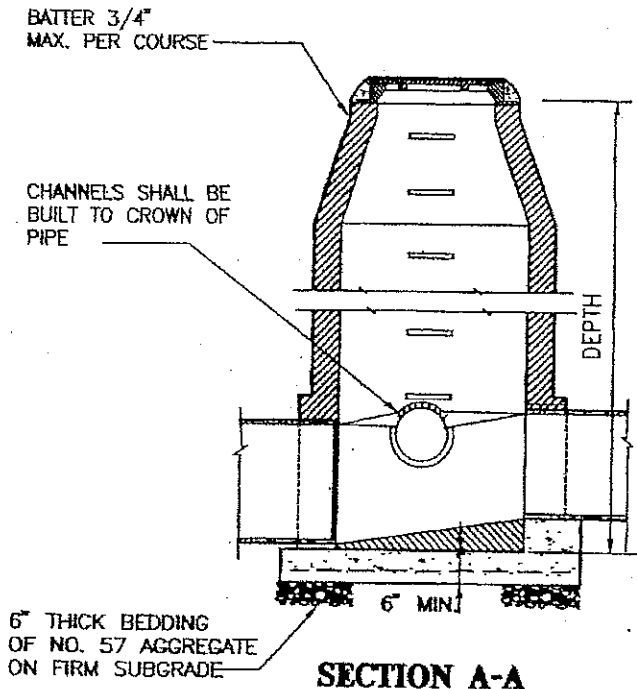

SECTION A-A

NOTES:

- FOR PIPES LARGER THAN 27", PROVIDE STEPS IN CHANNELS OF STRUCTURES - SEE SD110.0.
- PARGING IS REQUIRED FOR BRICK CONSTRUCTION IN ACCORDANCE WITH PRINCE GEORGE'S COUNTY, DEPARTMENT OF ENVIRONMENTAL RESOURCES STORMWATER STANDARDS AND SPECIFICATIONS.
- ALL MORTAR JOINTS ON OUTSIDE TO BE COMPLETELY FILLED WITH MORTAR.
- PRINCE GEORGE'S COUNTY, DEPARTMENT OF ENVIRONMENTAL RESOURCES APPROVAL IS REQUIRED FOR ALL SPECIAL DESIGN STRUCTURES
- CONCRETE COMPRESSION STRENGTH TO BE 4,000 psi AT 28 DAYS.
- FOR DEPTH GREATER THAN 16' A SPECIAL DESIGN IS REQUIRED.
- ALL REINFORCEMENT STEEL TO BE ASTM A615, GRADE 60.
- USE TRAFFIC BEARING FRAME AND COVER IN TRAFFIC AREA.
- ANY INCOMING PIPE SHALL NOT ENTER A MANHOLE AT ANY ANGLE LESS THAN 90° TO THE OUTFLOW PIPE, EXCEPT WHEN THE DIFFERENCE IN INVERT ELEVATION BETWEEN THE INFLOW AND OUTFLOW PIPES ARE GREATER THAN 2'.
- THE MINIMUM SPACING BETWEEN CONNECTIONS SHALL BE 2' IF INCOMING PIPES ARE AT THE SAME INVERT.



DEPARTMENT OF ENVIRONMENTAL RESOURCES
 APPROVED BY: *Ston E. Wildesen*
 Ston E. Wildesen, P.E.
 Assoc. Director
 DATE: 3/16/01

REVISION
JAN. 2001

STORM DRAIN
 TYPE "A" MASONRY
 MANHOLE

SD
 20.0

FOR FRAME AND COVER
DETAIL SEE SD 90.1
AND 90.3

2-#4 BARS @
TOP AND BOTTOM
AROUND OPENING

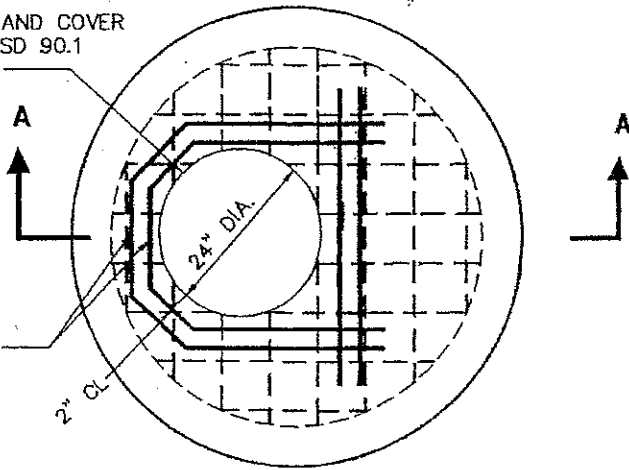

PLAN VIEW

TOP DIA.

2-#4 BARS @
TOP AND BOTTOM
AROUND OPENING

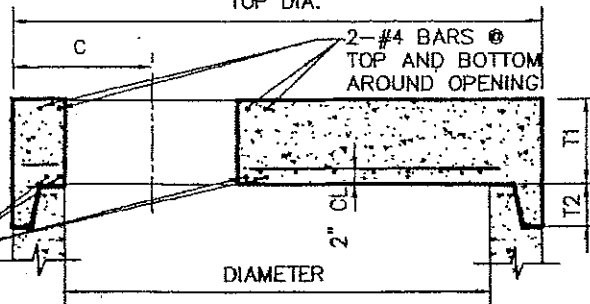

48", 60", AND 72" MANHOLES SECTION

2-#4 BARS @
TOP AND BOTTOM
AROUND OPENING

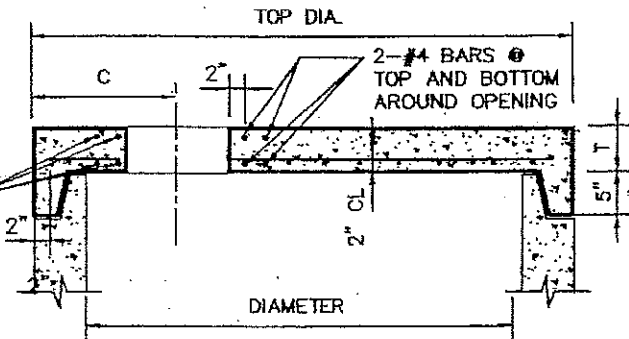

84" AND 96" MANHOLES SECTION

DIMENSIONS						
MH DIA.	C	TOP DIA.	REINFORCEMENT	T1	T2*	T
48"	20"	58"	#5 @ 6" C/C E.W.	6"	4"	-
60"	21"	72"	#5 @ 6" C/C E.W.	8"	4"	-
72"	22"	86"	#6 @ 6" C/C E.W.	8"	5"	-
84"	20"	100"	#6 @ 6" C/C E.W.	-	-	8"
96"	21"	114"	#6 @ 6" C/C E.W.	-	-	8"

*PER MANUFACTURER'S DESIGN



DEPARTMENT OF
ENVIRONMENTAL RESOURCES

APPROVED BY:

Stan E. Wildesen
Stan E. Wildesen, P.E.
Assoc. Director

DATE:

3/16/01

REVISION

JAN. 2001

STORM DRAIN
TOP SLAB FOR TYPE "A"
PRECAST MANHOLE

SD
210

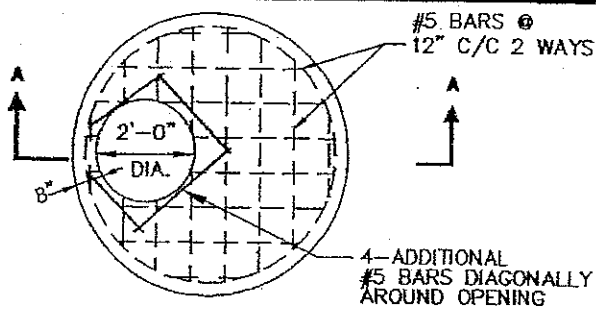

FLAT SLAB - TOP

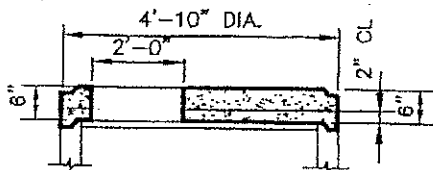

SECTION A-A

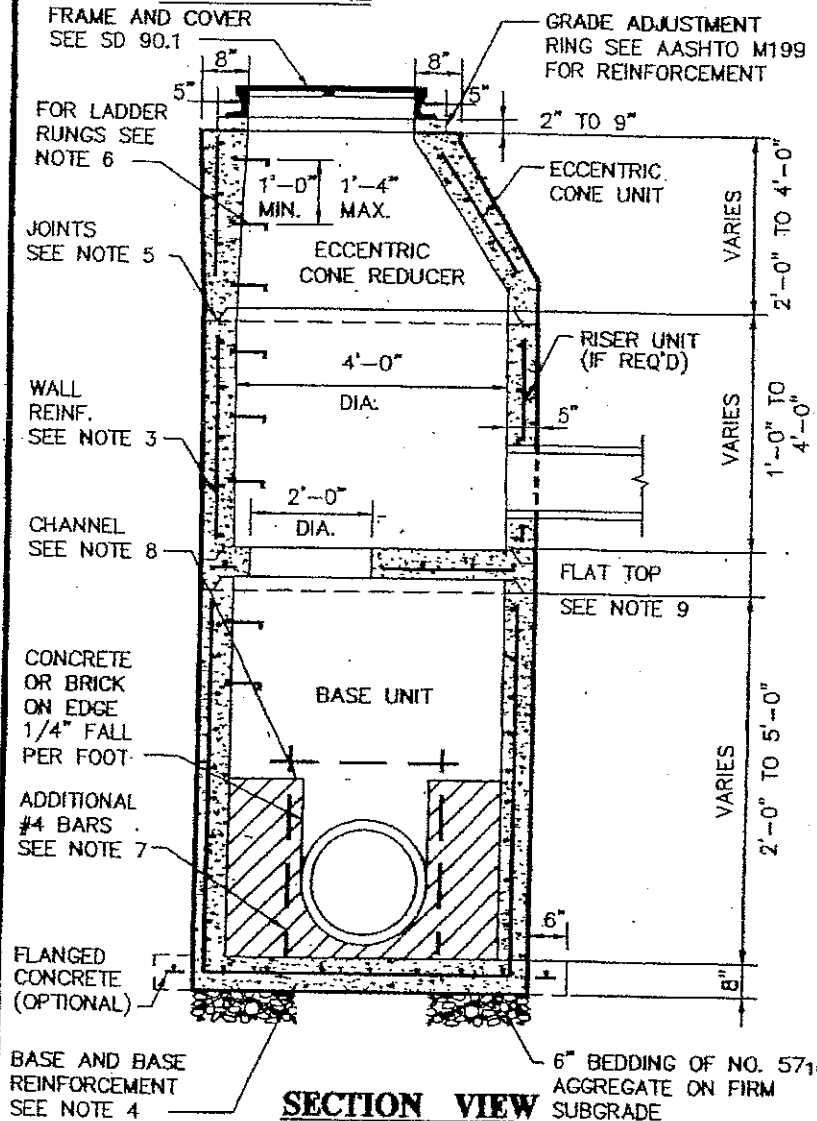

SECTION VIEW

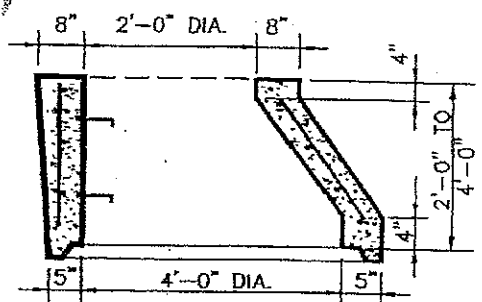

ECCENTRIC CONE REDUCER

(ALTERNATE FOR FLATTOP REDUCER)

NOTES:

1. MANHOLES SHALL BE CONSTRUCTED IN ACCORDANCE WITH AASHTO M199 AND ASTM C478.
2. CONCRETE TO BE $f'_c=5000$ @ 28 DAYS WITH AIR ENTRAINED.
3. WALL REINFORCEMENT FOR BASE UNITS, RISER UNITS AND ECCENTRIC CONE REDUCERS SHALL BE DEFORMED BARS OR WELDED WIRE FABRIC WITH A MINIMUM AREA OF 0.12 SQ. IN./FT. FOR 48" DIAMETER MANHOLES. WELDED WIRE FABRIC SHALL CONFORM TO ASTM A185 AND A82. DEFORMED REINFORCEMENT SHALL CONFORM TO ASTM A615 GRADE 60.
4. BASE REINFORCEMENT TO BE DEFORMED BARS OR WELDED WIRE FABRIC WITH A MINIMUM AREA OF 0.14 SQ. IN./FT. THE BASE MAY BE CAST MONOLITHIC WITH THE BASE UNIT OR JOINTED PER MANUFACTURER'S DESIGN. APPROVAL BY PRINCE GEORGE'S COUNTY, DEPARTMENT OF ENVIRONMENTAL RESOURCES, IS REQUIRED.
5. THE MANUFACTURER SHALL FORM MALE AND FEMALE ENDS OF JOINTS USING OWN DESIGN. THE JOINTS SHALL BE SEALED BY THE CONTRACTOR USING MORTAR AND MADE WATERTIGHT USING RUBBER O-RING GASKETS CONFORMING TO ASTM C361 AND C443 OR FLEXIBLE PLASTIC GASKETS CONFORMING TO AASHTO M198 (TYPE B).
6. LADDER RUNGS SHALL BE INSTALLED IN VERTICAL ALIGNMENT AT 1'-4" MAX. C/C RUNG TYPES SHALL BE IN ACCORDANCE WITH SD 80.0 (METAL LADDER RUNGS) OR SD 81.0 (COPOLYMER POLYPROPYLENE STEEL ENCAPSULATED LADDER RUNGS). PIPE CANNOT BE USED AS STEPS.
7. ADDITIONAL #4 BARS ARE TO BE USED AROUND ALL OPENINGS IN THE STRUCTURE.
8. $f'_c = 3000$ psi CONCRETE OR BRICK CHANNEL SHALL BE PROVIDED IN THE FIELD AND BE CONSTRUCTED UP TO CROWN OF PIPES.
9. THE FLAT TOP SLAB LANDING SHALL BE USED ONLY EVERY 12' INTERVAL REFER TO MDSA 384.13 FOR REINFORCEMENT DETAIL.

A SHOP DRAWING HAS TO BE APPROVED BY DER IF THE STRUCTURE IS MORE THAN 15' IN DEPTH.



DEPARTMENT OF ENVIRONMENTAL RESOURCES
 APPROVED BY: *Stan E. Wildesen*
 Stan E. Wildesen, P.E.
 Assoc. Director

DATE: 3/16/01

REVISION
JAN. 2001

**STORM DRAIN
 TYPE "A"
 48" DIA. PRECAST MANHOLE
 FOR 12"-24" PIPES**

**SD
 211**

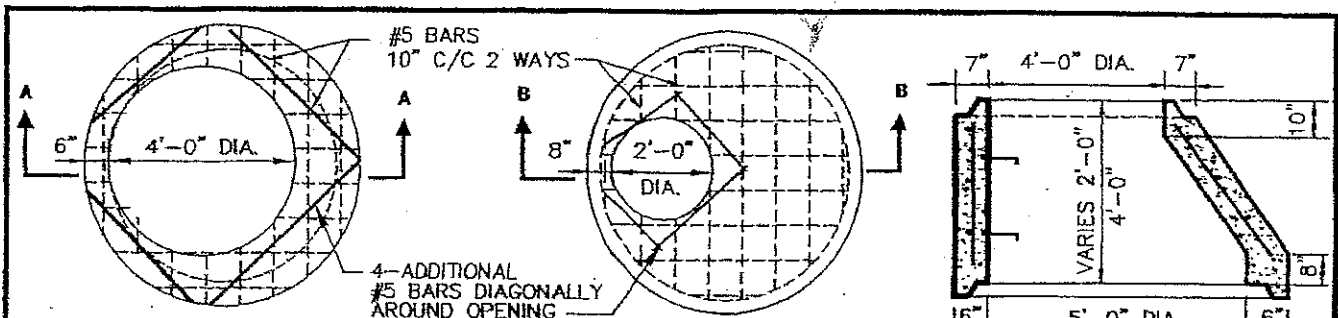

FLATTOP REDUCER

FLAT SLAB TOP

ECCENTRIC CONE REDUCER

(ALTERNATE FOR FLATTOP REDUCER)

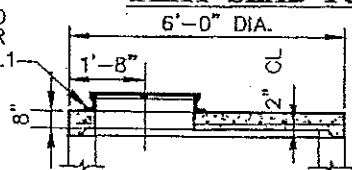
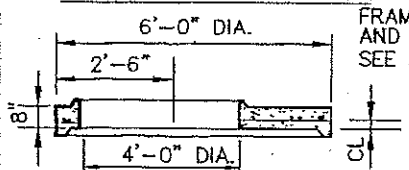

SECTION A-A

SECTION B-B

NOTES:

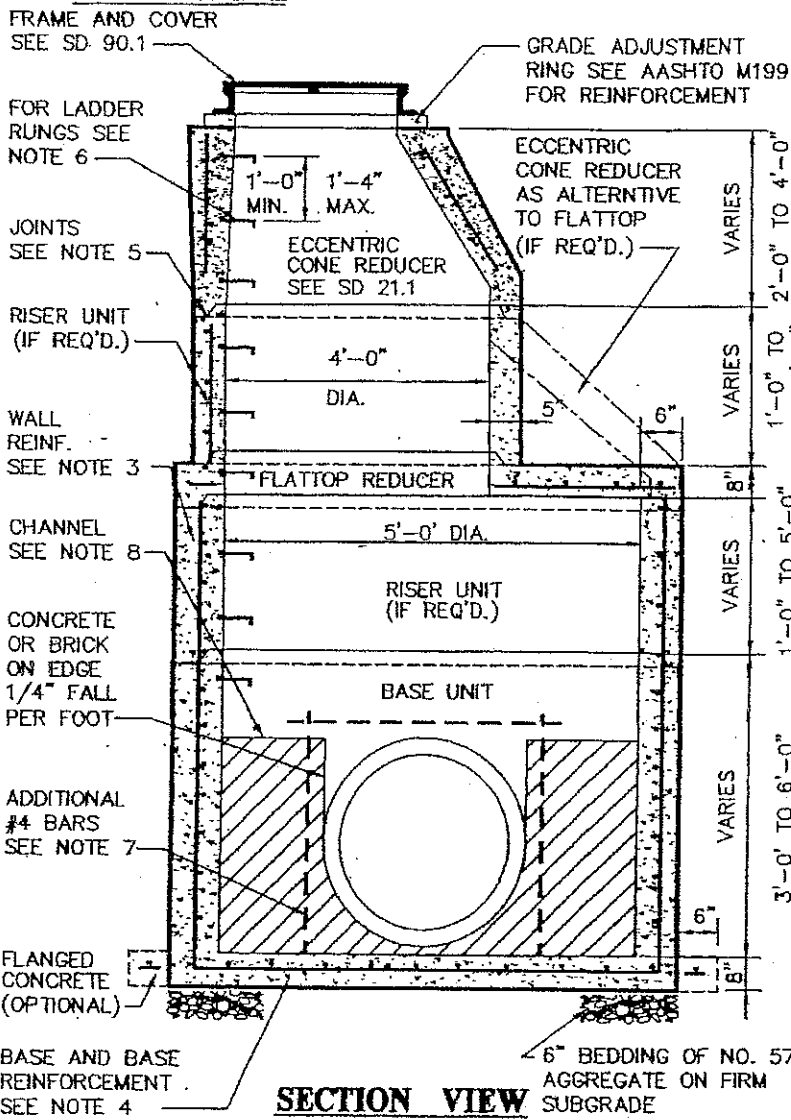

1. MANHOLES SHALL BE CONSTRUCTED IN ACCORDANCE WITH AASHTO M199 AND ASTM C478.
2. CONCRETE TO BE $f_c = 5000$ @ 28 DAYS WITH AIR ENTRAINED.
3. WALL REINFORCEMENT FOR BASE UNITS, RISER UNITS AND ECCENTRIC CONE REDUCERS SHALL BE DEFORMED BARS OR WELDED WIRE FABRIC WITH A MINIMUM AREA OF 0.15 SQ. IN./FT. FOR 60" DIAMETER MANHOLES. WELDED WIRE FABRIC SHALL CONFORM TO ASTM A185 AND A82. DEFORMED REINFORCEMENT SHALL CONFORM TO ASTM A615 GRADE 60.
4. BASE REINFORCEMENT TO BE DEFORMED BARS OR WELDED WIRE FABRIC WITH A MINIMUM AREA OF 0.17 SQ. IN./FT. THE BASE MAY BE CAST MONOLITHIC WITH THE BASE UNIT OR JOINTED PER MANUFACTURER'S DESIGN. APPROVAL BY PRINCE GEORGE'S COUNTY, DEPARTMENT OF ENVIRONMENTAL RESOURCES, IS REQUIRED.
5. THE MANUFACTURER SHALL FORM MALE AND FEMALE ENDS OF JOINTS USING OWN DESIGN. THE JOINTS SHALL BE SEALED BY THE CONTRACTOR USING MORTAR AND MADE WATERTIGHT USING RUBBER O-RING GASKETS CONFORMING TO ASTM C361 AND C443 OR FLEXIBLE PLASTIC GASKETS CONFORMING TO AASHTO M198 (TYPE B).
6. LADDER RUNGS SHALL BE INSTALLED IN VERTICAL ALIGNMENT AT 1'-4" MAX. C/C RUNG TYPES SHALL BE IN ACCORDANCE WITH SD 80.0 (METAL LADDER RUNGS) OR SD 81.0 (COPOLYMER POLYPROPYLENE STEEL ENCAPSULATED LADDER RUNGS). PIPE CANNOT BE USED AS STEP.
7. ADDITIONAL #4 BARS ARE TO BE USED AROUND ALL OPENINGS IN THE STRUCTURE.
8. $f_c = 3000$ psi CONCRETE OR BRICK CHANNEL SHALL BE PROVIDED IN THE FIELD AND BE CONSTRUCTED UP TO THE CROWN OF PIPES.
9. A SHOP DRAWING HAS TO BE APPROVED BY DER IF THE STRUCTURE IS MORE THAN 20' IN DEPTH.
10. THE FLAT TOP REDUCER SHALL BE USED ONLY AT EVERY 12' INTERVALS.

SECTION VIEW



DEPARTMENT OF ENVIRONMENTAL RESOURCES
 APPROVED BY: *Ston E. Wildesen*
 DATE: 3/16/01
 Ston E. Wildesen, P.E.
 Assoc. Director

REVISION
JAN. 2001

STORM DRAIN
TYPE "A"
60" DIA. PRECAST MANHOLE
FOR 27"-36" PIPES

SD
21.2

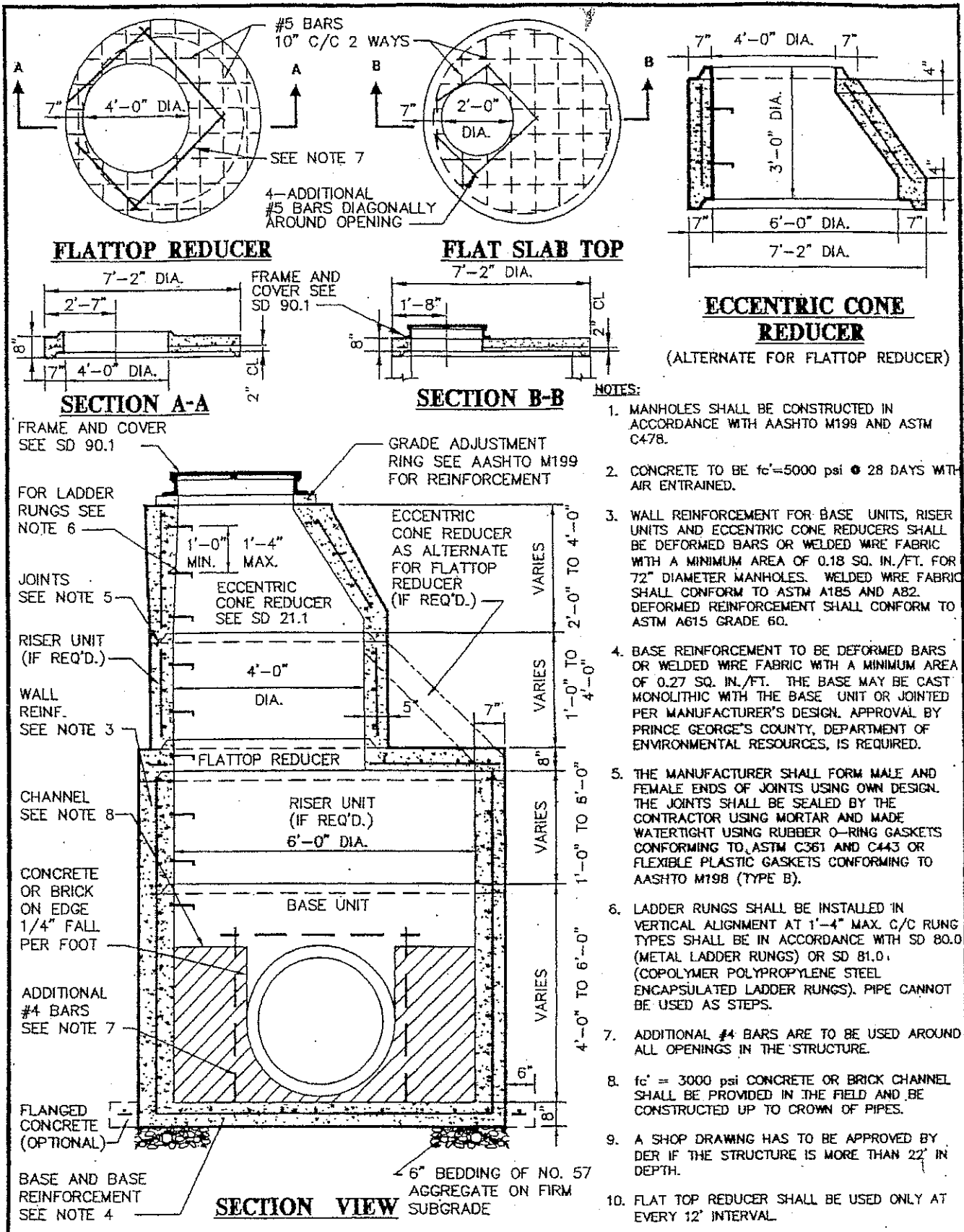

DEPARTMENT OF ENVIRONMENTAL RESOURCES

APPROVED BY: *Stan E. Wildesen*

Stan E. Wildesen, P.E.
Assoc. Director

DATE: 3/16/07

REVISION
JAN. 2001

STORM DRAIN
TYPE "A"
72" DIA. PRECAST MANHOLE
FOR 42"-48" PIPES

SD
21.3

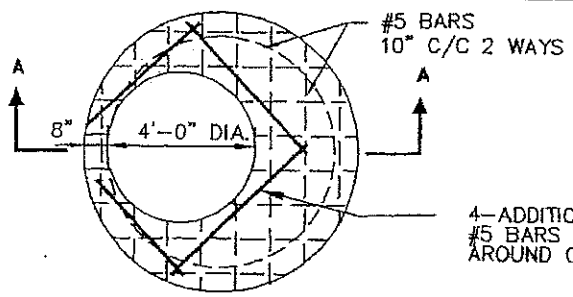

FLATTOP REDUCER

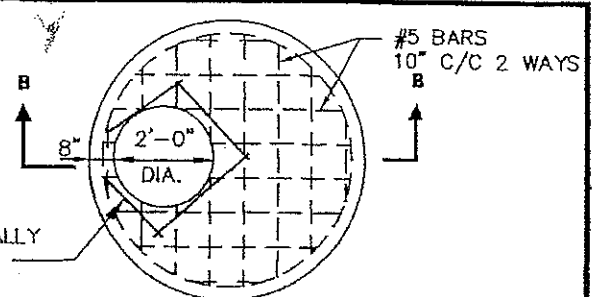
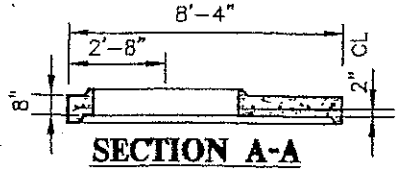

FLAT SLAB TOP

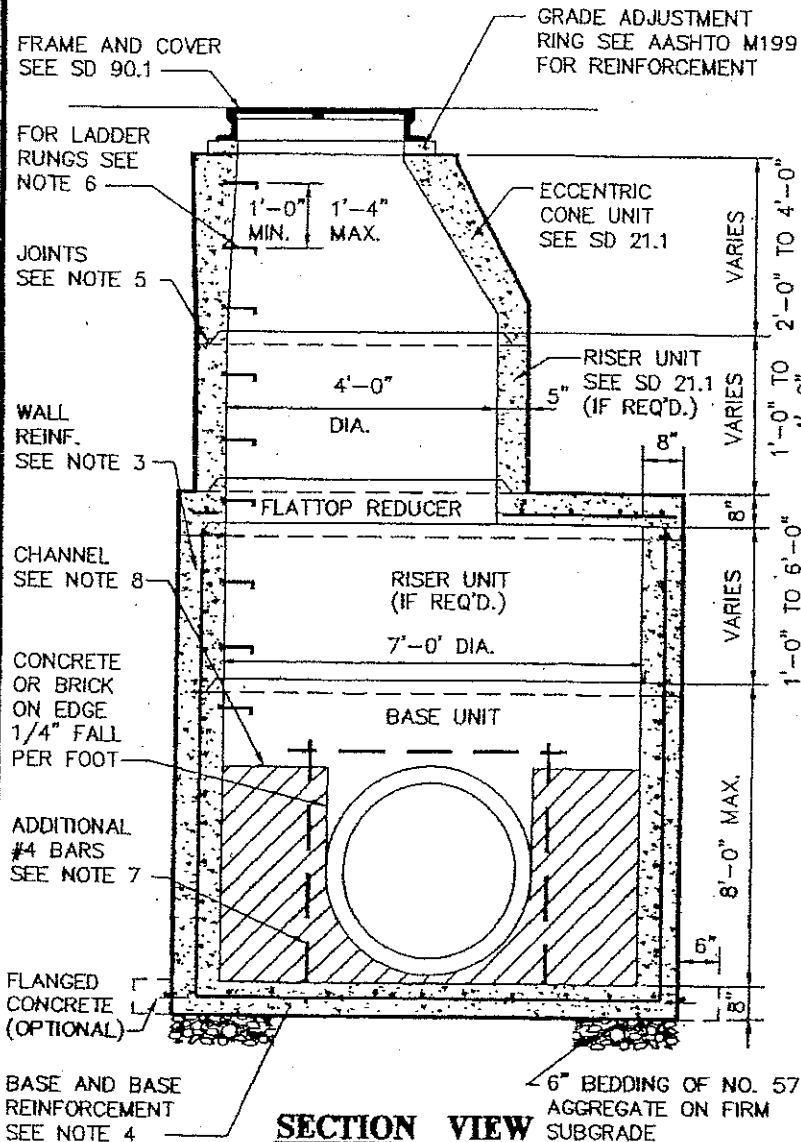
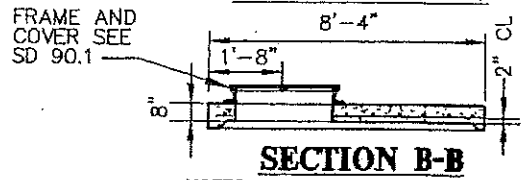

- NOTES:**
- MANHOLES SHALL BE CONSTRUCTED IN ACCORDANCE WITH AASHTO M199 AND ASTM C478.
 - CONCRETE TO BE $f_c' = 5000$ @ 28 DAYS WITH AIR ENTRAINED.
 - WALL REINFORCEMENT FOR BASE UNITS, RISER UNITS AND ECCENTRIC CONE REDUCERS SHALL BE DEFORMED BARS OR WELDED WIRE FABRIC WITH A MINIMUM AREA OF 0.21 SQ. IN./FT. FOR 84" DIAMETER MANHOLES. WELDED WIRE FABRIC SHALL CONFORM TO ASTM A185 AND A82. DEFORMED REINFORCEMENT SHALL CONFORM TO ASTM A615 GRADE 60.
 - BASE REINFORCEMENT TO BE DEFORMED BARS OR WELDED WIRE FABRIC WITH A MINIMUM AREA OF 0.27 SQ. IN./FT. THE BASE MAY BE CAST MONOLITHIC WITH THE BASE UNIT OR JOINTED PER MANUFACTURER'S DESIGN. APPROVAL BY PRINCE GEORGE'S COUNTY, DEPARTMENT OF ENVIRONMENTAL RESOURCES IS REQUIRED.
 - THE MANUFACTURER SHALL FORM MALE AND FEMALE ENDS OF JOINTS USING OWN DESIGN. THE JOINTS SHALL BE SEALED BY THE CONTRACTOR USING MORTAR AND MADE WATERTIGHT USING RUBBER O-RING GASKETS CONFORMING TO ASTM C361 AND C443 OR FLEXIBLE PLASTIC GASKETS CONFORMING TO AASHTO M198 (TYPE B).
 - LADDER RUNGS SHALL BE INSTALLED IN VERTICAL ALIGNMENT AT 1'-4" MAX. C/C RUNG TYPES SHALL BE IN ACCORDANCE WITH SD 81.0 (METAL LADDER RUNGS) OR SD 81.0 (COPOLYMER POLYPROPYLENE STEEL ENCAPSULATED LADDER RUNGS). PIPE CAN NOT BE USED AS STEPS.
 - ADDITIONAL #4 BARS ARE TO BE USED AROUND ALL OPENINGS IN THE STRUCTURE.
 - $f_c' = 3000$ psi CONCRETE OR BRICK CHANNEL SHALL BE PROVIDED IN THE FIELD AND BE CONSTRUCTED UP TO CROWN OF PIPE.
 - A SHOP DRAWING HAS TO BE APPROVED BY DER IF THE STRUCTURE IS MORE THAN 24' IN DEPTH.
 - THE FLAT TOP REDUCER SHALL BE ONLY USED AT EVERY 12' INTERVAL.

	DEPARTMENT OF ENVIRONMENTAL RESOURCES APPROVED BY: <i>Ston E. Wildesen</i> Ston E. Wildesen, P.E. Assoc. Director	REVISION JAN. 2001	STORM DRAIN TYPE "A" 84" DIA. PRECAST MANHOLE FOR 54"-66" PIPES	SD 21.4
	DATE: 3/16/01			

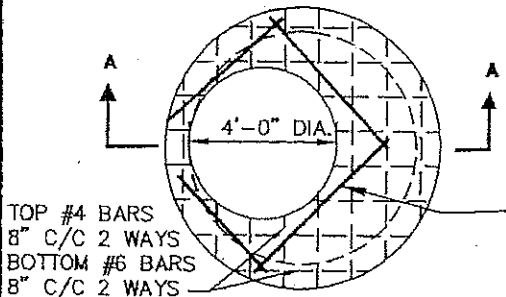

TOP #4 BARS
8" C/C 2 WAYS
BOTTOM #6 BARS
8" C/C 2 WAYS

4-ADDITIONAL
#5 BARS DIAGONALLY
AROUND OPENING

FLATTOP REDUCER

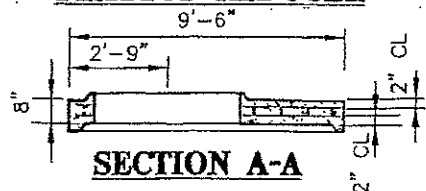

SECTION A-A

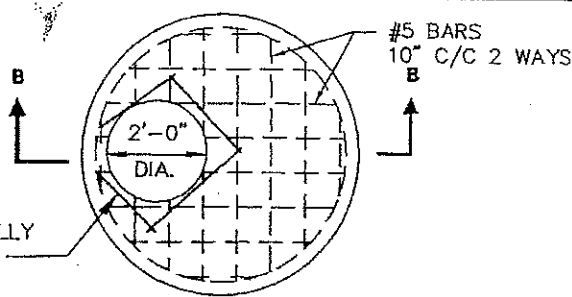

#5 BARS
10" C/C 2 WAYS

FLAT SLAB TOP

FRAME AND COVER
SEE SD 90.1

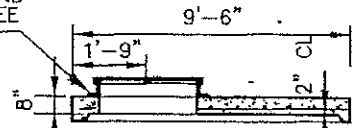

SECTION B-B

NOTES:

1. MANHOLES SHALL BE CONSTRUCTED IN ACCORDANCE WITH AASHTO M199 AND ASTM C478.
2. CONCRETE TO BE $f_c' = 5000$ @ 28 DAYS WITH AIR ENTRAINED.
3. WALL REINFORCEMENT FOR BASE UNITS, RISER UNITS AND ECCENTRIC CONE REDUCERS SHALL BE DEFORMED BARS OR WELDED WIRE FABRIC WITH A MINIMUM AREA OF 0.24 SQ. IN./FT. FOR 84" DIAMETER MANHOLES. WELDED WIRE FABRIC SHALL CONFORM TO ASTM A185 AND A82. DEFORMED REINFORCEMENT SHALL CONFORM TO ASTM A615 GRADE 60.
4. BASE REINFORCEMENT TO BE DEFORMED BARS OR WELDED WIRE FABRIC WITH A MINIMUM AREA OF 0.28 SQ. IN./FT. THE BASE MAY BE CAST MONOLITHIC WITH THE BASE UNIT OR JOINTED PER MANUFACTURER'S DESIGN. APPROVAL BY PRINCE GEORGE'S COUNTY, DEPARTMENT OF ENVIRONMENTAL RESOURCES IS REQUIRED.
5. THE MANUFACTURER SHALL FORM MALE AND FEMALE ENDS OF JOINTS USING OWN DESIGN. THE JOINTS SHALL BE SEALED BY THE CONTRACTOR USING MORTAR AND MADE WATERTIGHT USING RUBBER O-RING GASKETS CONFORMING TO ASTM C361 AND C443 OR FLEXIBLE PLASTIC GASKETS CONFORMING TO AASHTO M198 (TYPE B).
6. LADDER RUNGS SHALL BE INSTALLED IN VERTICAL ALIGNMENT AT 1'-4" MAX. RUNG C/C TYPES SHALL BE IN ACCORDANCE WITH SD 80.0 (METAL LADDER RUNGS) OR SD 81.0 (COPOLYMER POLYPROPYLENE STEEL ENCAPSULATED LADDER RUNGS). PIPE CAN NOT BE USED AS STEPS.
7. ADDITIONAL #4 BARS ARE TO BE USED AROUND ALL OPENINGS IN THE STRUCTURE.
8. $f_c' = 3000$ psi CONCRETE OR BRICK CHANNEL SHALL BE PROVIDED IN THE FIELD AND BE CONSTRUCTED UP TO CROWN OF PIPES.
9. A SHOP DRAWING HAS TO BE APPROVED BY DER IF THE STRUCTURE IS MORE THAN 24' IN DEPTH.
10. THE FLAT TOP REDUCER SHALL BE USED AT ONLY EVERY 12' INTERVALS.

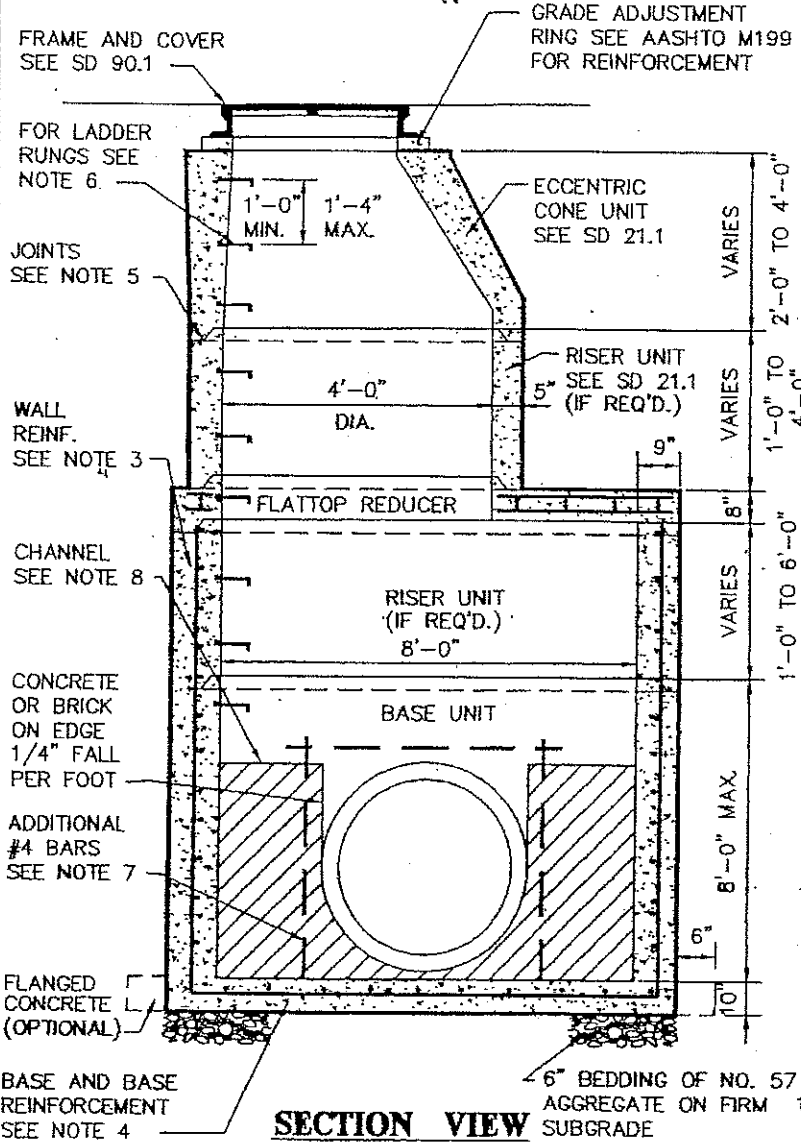

SECTION VIEW



DEPARTMENT OF ENVIRONMENTAL RESOURCES
APPROVED BY:
Ston E. Wildesen, P.E.
Ston E. Wildesen, P.E.
Assoc. Director
DATE: 3/16/01

REVISION
JAN. 2001

STORM DRAIN
TYPE "A"
96" DIA. PRECAST MANHOLE
FOR A 72" PIPE

SD
21.5

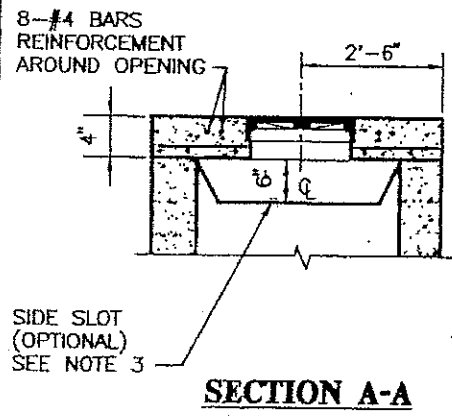
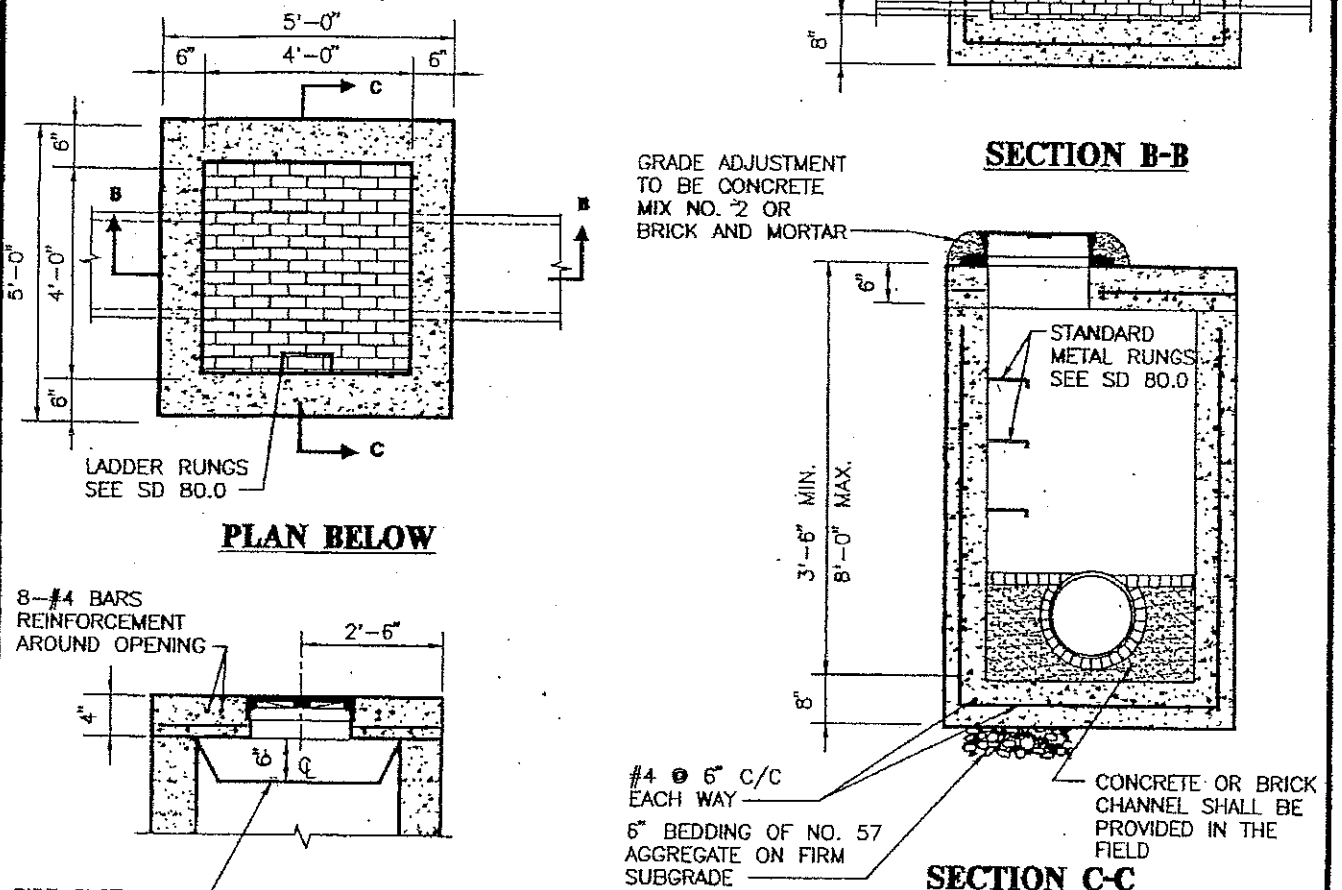
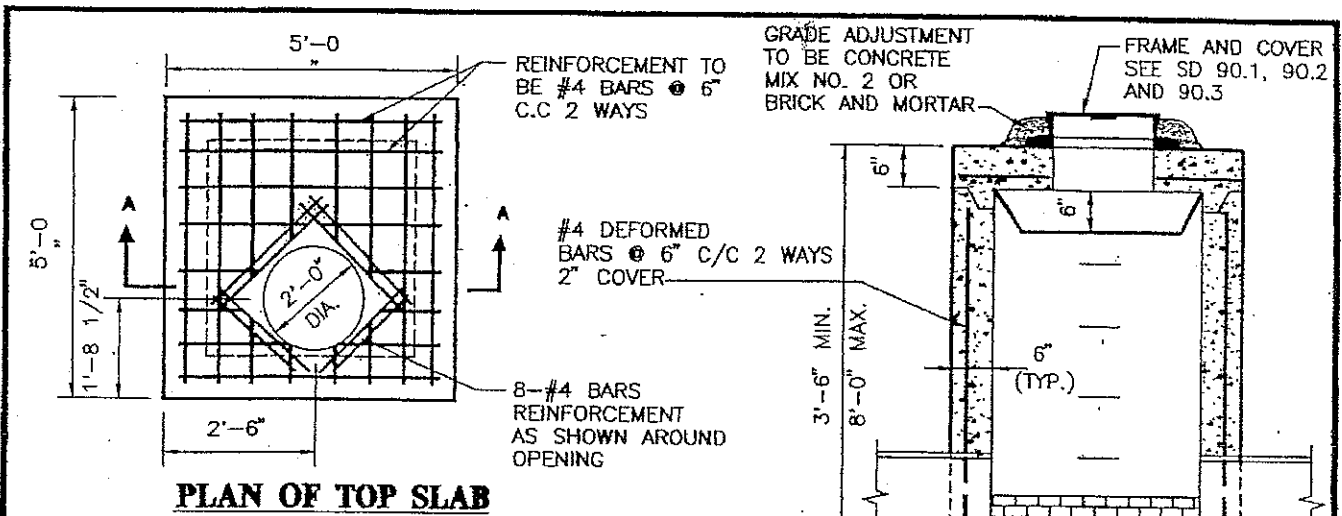

- NOTES:**
1. THE CONSTRUCTION OF THE STRUCTURE MUST BE IN ACCORDANCE WITH PRINCE GEORGE'S COUNTY, DEPARTMENT OF ENVIRONMENTAL RESOURCES, STORMWATER STANDARDS AND SPECIFICATIONS.
 2. ALL REINFORCING STEEL TO BE ASTM A615 GRADE 60.
 3. PROVIDE 8 ADDITIONAL #4 BARS REINFORCEMENT FOR PIPE OPENINGS AND SLOTS.
 4. $f_c' = 5,000$ psi FOR PRECAST @ 28 DAYS WITH AIR ENTRAINED.
 5. FOR TRAFFIC AREA, TOP SLAB AND FRAME AND COVER MUST BEAR HS20 LOADING.

 <p>DEPARTMENT OF ENVIRONMENTAL RESOURCES</p> <p>APPROVED BY:</p> <p><i>Ston E. Willesen</i></p> <p>Ston E. Willesen, P.E. Assoc. Director</p>	<p>REVISION</p> <p>JAN. 2001</p>	<p>STORM DRAIN</p> <p>TYPE "B" PRECAST</p> <p>SHALLOW MANHOLE</p>	<p>SD</p> <p>22.0</p>
	<p>DATE:</p> <p>3/16/01</p>		

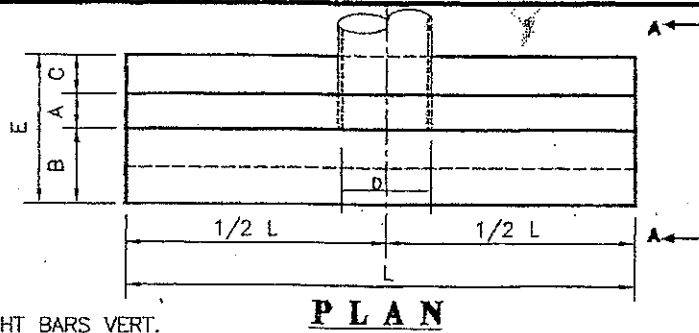

PLAN

4-#4 STRAIGHT BARS VERT.
IN FRONT FACE FOR 15" DIA.
TO 21" DIA. PIPE ENDWALLS
INCLUSIVE

2-#4 STRAIGHT BARS HORIZ.
1 EACH FACE FOR 36" DIA.
TO 72" DIA. PIPE ENDWALLS
INCLUSIVE

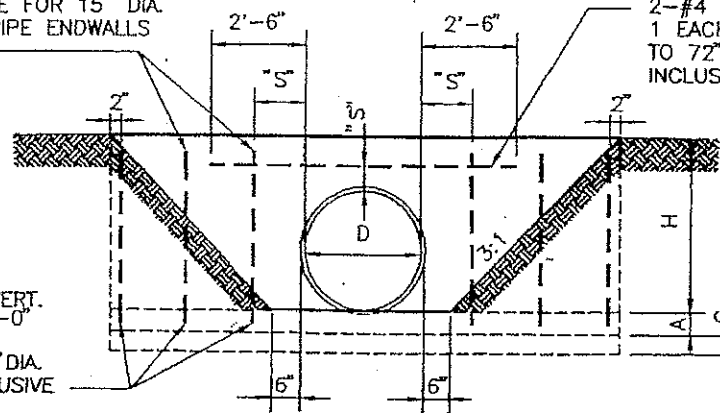

#4 STRAIGHT BARS VERT.
@ 1'-6" MIN. TO 2'-0"
MAX. IN FRONT FACE
FOR 24" DIA. TO 72" DIA.
PIPE ENDWALLS INCLUSIVE

ELEVATION

#4 BENT BARS HORIZ.
@ 1'-0" C/C BOTH SIDERS
OF OPENING FOR 36" DIA.
TO 72" DIA. PIPE ENDWALLS
INCLUSIVE

#4 STRAIGHT BARS HORIZ.
@ 1'-7" MAX. C/C BOTH
FACES TOP AND BOTTOM
BARS TO BE FULL LENGTH
ALL ENDWALLS

#4 BENT BARS @ 1'-0" C/C
ALL ENDWALLS

#4 @ 12" C/C

4-#4 HORIZ.
BARS

2-#4 STRAIGHT BARS
HORIZ. FOR 36" DIA. TO
72" DIA. PIPE ENDWALLS
INCLUSIVE

SECTION A-A

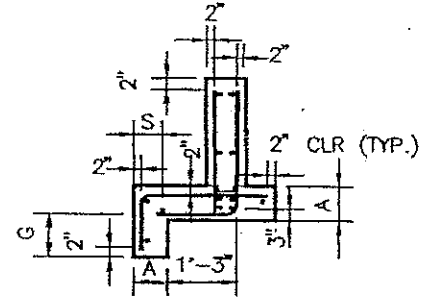

DISPOSITION OF BARS

OPENING		DIMENSIONS									
D INCHES	AREA SQ. FT.	A	B	C	E	F	G	H	3:1 SLOPE L	2:1 SLOPE L	S
15	1.23	9"	10"	6"	2'-1"	12"	2'-0"	2'-3"	15'-9"	11'-3"	4"
18	1.77	9"	10"	6"	2'-1"	12"	2'-0"	2'-6"	17'-6"	12'-6"	4"
21	2.40	9"	10"	6"	2'-1"	12"	2'-0"	2'-9"	19'-3"	13'-9"	4"
24	3.14	9"	14"	6"	2'-5"	12"	2'-0"	3'-0"	21'-0"	15'-0"	6"
27	3.98	9"	14"	6"	2'-5"	12"	2'-0"	3'-3"	22'-9"	16'-3"	6"
30	4.91	9"	14"	6"	2'-5"	12"	2'-0"	3'-6"	24'-6"	17'-6"	6"
33	5.94	9"	14"	6"	2'-5"	12"	3'-0"	3'-9"	26'-3"	18'-9"	6"
36	7.07	12"	16"	10"	3'-2"	12"	3'-0"	4'-0"	28'-0"	20'-0"	6"
42	9.62	12"	16"	10"	3'-2"	12"	3'-0"	4'-6"	31'-6"	22'-6"	8"
48	12.57	12"	16"	10"	3'-2"	12"	3'-0"	5'-0"	35'-0"	25'-0"	8"
54	15.90	12"	20"	12"	3'-8"	12"	3'-0"	5'-6"	38'-6"	27'-6"	8"
60	19.64	12"	20"	12"	3'-8"	12"	3'-0"	6'-0"	42'-0"	30'-0"	8"
72	28.27	12"	20"	12"	3'-8"	12"	3'-0"	7'-0"	49'-0"	35'-0"	8"

NOTES:

1. UNLESS OTHERWISE SPECIFIED, THE SIDE SLOPE 2:1 MAXIMUM TO BOTTOM OF THE OUTFALL CHANNEL. KEEP 6" AWAY FROM STORM DRAIN PIPE.
2. $f_c' = 5,000$ psi @ 28 DAYS WITH AIR ENTRAINMENT FOR PRECAST CONCRETE. $f_c' = 4,000$ psi WITH AIR ENTRAINMENT FOR CAST IN PLACE.
3. PROVIDE 6" THICK OF NO. 57 AGGREGATE BEDDING ON FIRM SUBGRADE.
4. 2" MINIMUM CONCRETE CLEARANCE.

QUANTITIES IN THIS TABLE TO BE USED FOR ESTIMATING ONLY



DEPARTMENT OF
ENVIRONMENTAL RESOURCES

APPROVED BY: *Stan E. Wildesen* DATE: 3/16/01
Stan E. Wildesen, P.E.
Assoc. Director

REVISION
JAN. 2001

STORM DRAIN
ENDWALL

SD
30.0

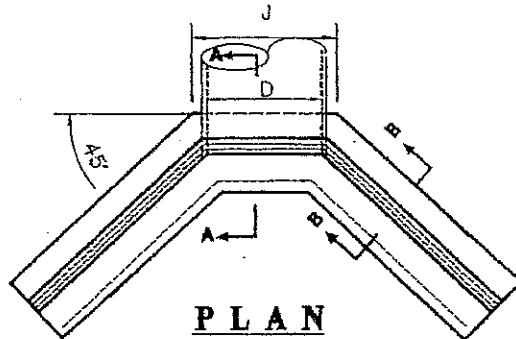

PLAN

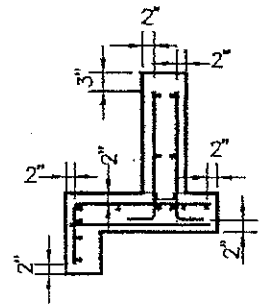

DISPOSITION OF BARS

4-#6 BENT BARS HORIZ.
2 EACH FACE

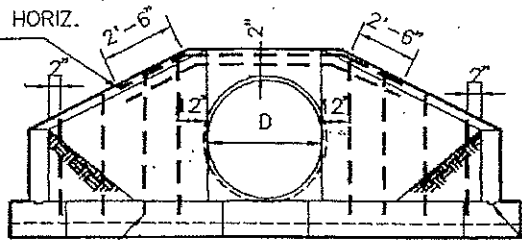

ELEVATION

#4 STRAIGHT BARS VERT.
@ 1'-6" MIN. TO 2'-0"
MAX. ON FRONT FACE

PROVIDE
2" x 6" KEYWAY
(TYP.)

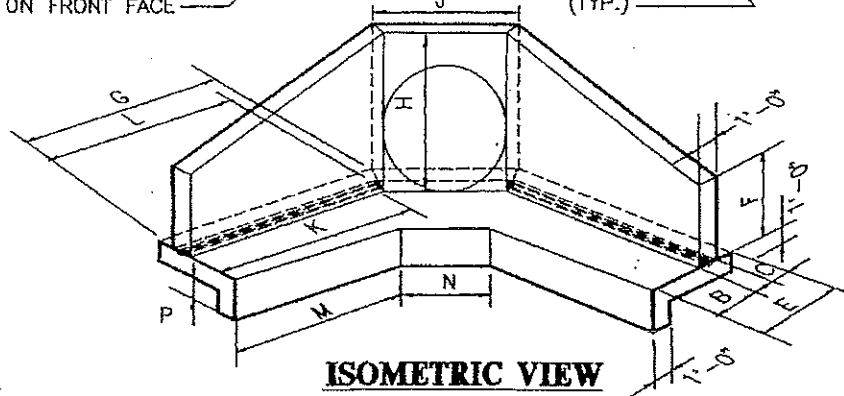

ISOMETRIC VIEW

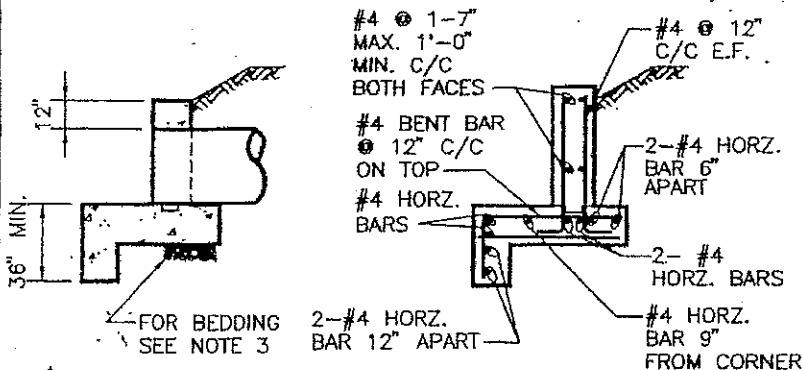

SECTION A-A

SECTION B-B

NOTES:

1. FOR MORE DETAILS AND NOTES SEE SD 30.0
2. UNLESS OTHERWISE SPECIFIED THE MAX. SIDE SLOPE IS 2:1 TO THE BOTTOM OF THE OUTFALL CHANNEL.
3. PROVIDE 6" THICK OF NO. 57 AGGREGATE BEDDING ON FIRM SUBGRADE.
4. $f_c' = 5,000$ psi @ 28 DAYS WITH AIR ENTRAINED.
5. 2" MINIMUM CONCRETE CLEARANCE.

OPENING		DIMENSIONS											
D INCHES	AREA SQ. FT.	B	C	E	F	G	H	J	K	L	M	N	P
48	12.57	1'-4"	10"	3'-2"	2'-8"	7'-3/4"	5'-0"	4'-10"	6'-3 1/2"	6'-8 1/2"	5'-9"	2'-10 3/4"	2'-0"
54	15.90	1'-8"	1'-0"	3'-8"	3'-0"	7'-8 1/2"	5'-5"	5'-4"	6'-10 1/2"	7'-3 1/2"	6'-2 1/4"	3'-1 1/2"	2'-0"
60	19.64	1'-8"	1'-0"	3'-8"	3'-3"	8'-5"	6'-0"	5'-10"	7'-7 1/4"	8'-1/4"	6'-11"	3'-7 1/2"	2'-0"

QUANTITIES IN THIS TABLE TO BE USED FOR ESTIMATING ONLY



DEPARTMENT OF ENVIRONMENTAL RESOURCES

APPROVED BY: *Ston E. Wildesen*
Ston E. Wildesen, P.E.
Assoc. Director

DATE: 3/16/01

REVISION
JAN. 2001

STORM DRAIN
TYPE "A" HEADWALL FOR
48", 54", AND 60" PIPE

SD
31.0

DIA. 66" TO 72"
 #4 LONG BENT BARS HORIZ.
 #4 SHORT BENT BARS HORIZ.
 ALT. 1 WITH 1 @ 6" C/C

DIA. 78" TO 84"
 #4 LONG BENT BARS HORIZ.
 #4 SHORT BENT BARS HORIZ.
 ALT. 1 WITH 2 RESP. @ 4" C/C

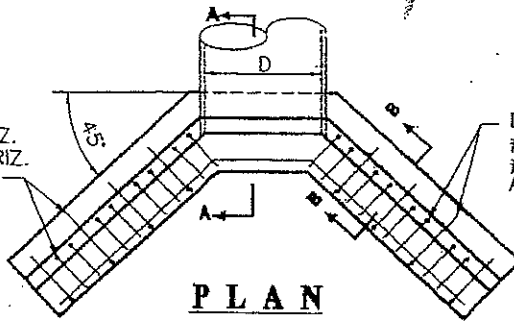

PLAN

4-#6 BENT BARS HORIZ.
 2 EACH FACE

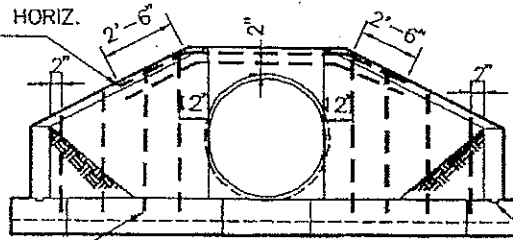

ELEVATION

#4 STRAIGHT BARS VERT.
 @ 1'-6" MIN. TO 2'-0"
 MAX. IN FRONT FACE

PROVIDE
 2'x6" KEYWAY
 (TYP.)

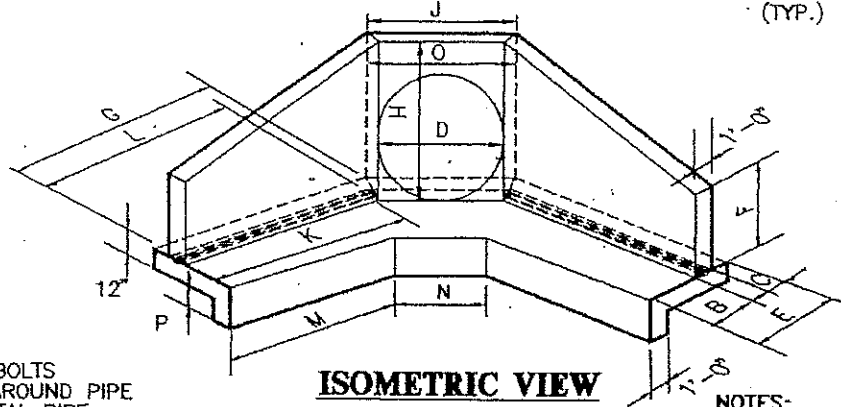

ISOMETRIC VIEW

3/4" O HOOK BOLTS
 @ 1'-6" C/C AROUND PIPE
 ARCH WHEN METAL PIPE
 IS USED

12" MIN.
 OVER PIPE

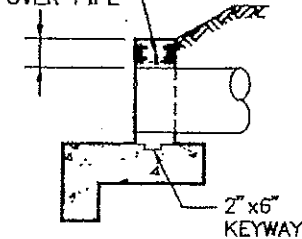

SECTION A-A

#4 BARS HORIZ. @
 1'-7" @ MAX C/C
 BOTH FACES BOTTOM
 BARS BENT ALONG
 ENDWALL OTHERS
 STRAIGHT

#4 BENT BARS
 AT 12" C/C

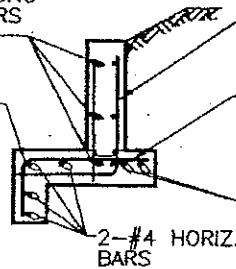

SECTION B-B

#4 BENT BARS BOTH
 WINGWALLS ALL
 ENDWALLS

#4 BENT BARS @ 1'-0" C/C
 BOTH SIDES OF OPENING

2-#4 HORIZ.
 STRA. BARS

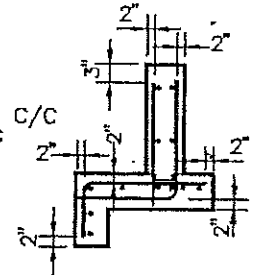

NOTES:

1. REFER TO SD 30.0 FOR NOTES.

OPENING		DIMENSIONS												
D INCHES	AREA SQ. FT.	B	C	E	F	G	H	J	K	L	M	N	O	P
66	23.80	2'-6"	1'-3"	4'-9"	3'-0"	11'-2 1/2"	6'-8 1/2"	6'-4"	10'-3 1/4"	10'-8 1/2"	9'-3"	3'-5"	7'-4 1/2"	2'-0"
72	28.27	2'-6"	1'-3"	4'-9"	3'-3"	12'-1"	7'-3"	6'-10"	11'-1 3/4"	11'-6 3/4"	10'-1 1/4"	3'-11"	7'-10 1/2"	2'-0"
78	33.20	3'-0"	1'-6"	5'-6"	3'-6"	13'-1 1/2"	7'-9 1/2"	7'-4"	12'-0"	12'-5"	10'-9"	4'-0"	8'-6 3/4"	2'-6"
84	38.48	3'-0"	1'-6"	5'-6"	3'-9"	13'-10"	8'-4"	7'-10"	12'-9 1/2"	13'-2 1/2"	11'-6 1/2"	4'-6"	9'-0"	2'-6"



DEPARTMENT OF
 ENVIRONMENTAL RESOURCES

APPROVED BY:

Stan E. Wildesen
 Stan E. Wildesen, P.E.
 Assoc. Director

DATE:

3/16/01

REVISION

JAN. 2001

STORM DRAIN
 TYPE "B" HEADWALL FOR
 66", 72", 78", 84" DIA. PIPES

SD
 32.0

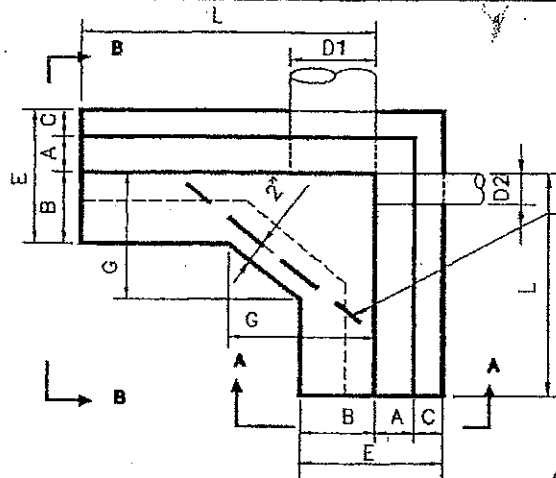

PLAN

2-#4 STRAIGHT BARS
VERT. IN FRONT
FACE FOR 15" DIA. TO
18" DIA. PIPE END
WALLS INCLUSIVE

2-#4 STRAIGHT BARS
HORIZONTAL
1 TOP, 1 BOTTOM
ALL ENDWALLS

#4 BARS HORIZ. @ 1'-7"
MAX. C/C BOTH FACES-
LAP 1'-3" TOP & BOTTOM
BARS @ CORNER BOTH
WINGWALLS ALL ENDWALLS

#4 STRAIGHT BARS
VERT. @ 1'-6" MIN.
TO 2'-0" MAX. FRONT
FACE FOR 24" TO 60"
DIA. PIPE ENDWALL
INCLUSIVE

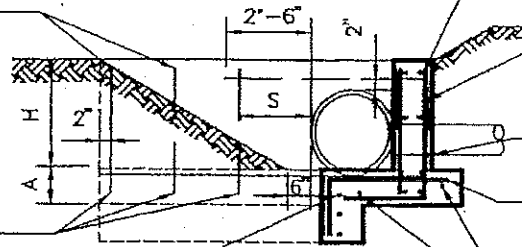

SECTION A-A

2-#4 STRAIGHT BARS
HORIZ. 1 EACH WINGWALL
ALL ENDWALLS

#4 BENT BARS @ 1'-0"
C/C BOTH WINGWALLS
ALL ENDWALLS

ELEVATION OF INVERT
AS DIRECTED

#4 STRAIGHT BARS HORIZ.
@ 1'-0" C/C BOTH SIDES
OF OPENING FOR 36" TO
48" DIA. PIPE ENDWALLS

4-#4 STRAIGHT BARS HORIZ.
2 EACH WINGWALL FOR 36"
TO 48" DIA. PIPE ENDWALLS
INCLUSIVE

2-#4 BENT BARS
HORIZ. 1 EACH
FACE

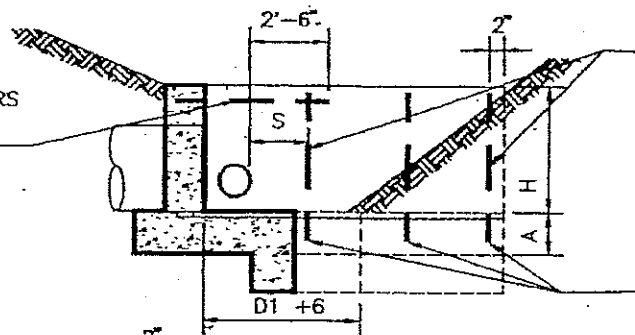

SECTION B-B

2-#4 STRAIGHT BARS
VERT. IN FRONT
FACE FOR 15" TO 18" DIA.
PIPE ENDWALLS
INCLUSIVE

#4 STRAIGHT BARS
VERT. @ 1'-6" MIN.
TO 2'-0" MAX. FRONT
FACE FOR 24" TO 60"
DIA. PIPE ENDWALL
INCLUSIVE

TOE WALL
SEE SD 32.0

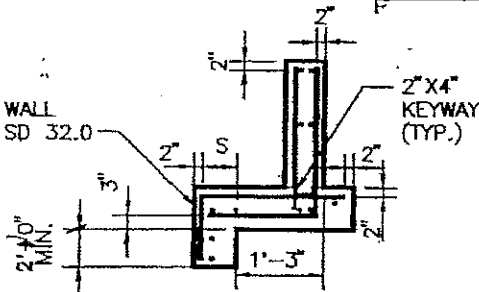

DISPOSITION OF BARS

NOTES:

1. REFER TO SD 30.0 FOR OTHER NOTES.
2. "S" DISTANCE FROM INSIDE SURFACE TO PIPE TO VERTICAL BARS IN FRONT AND REAR FACE
4" FOR 15" DIA. TO 18" DIA. PIPES INCLUSIVE
6" FOR 24" DIA. TO 36" DIA. PIPES INCLUSIVE
8" FOR 42" DIA. TO 48" DIA. PIPES INCLUSIVE
3. FOR DIMENSION TABLE SEE SD 33A.0



DEPARTMENT OF
ENVIRONMENTAL RESOURCES

APPROVED BY:

Ston E. Willesen
Ston E. Willesen, P.E.
Assoc. Director

DATE:
3/16/01

REVISION

JAN. 2001

STORM DRAIN
TYPE "H"
ENDWALL

SD
33.0

QUANTITY TABLE									
D1	D2	A	B	C	E	H	3:1 SLOPE L	2:1 SLOPE L	G
15"	15"	9"	6"	6"	1'-9"	2'-0"	7'-9"	5'-9"	2'-0"
18"	15"	9"	6"	6"	1'-9"	2'-3"	8'-9"	6'-6"	2'-3"
18"	18"	9"	6"	6"	1'-9"	2'-3"	8'-9"	6'-6"	2'-3"
24"	15"	9"	14"	6"	2'-5"	2'-9"	10'-9"	8'-0"	3'-0"
24"	18"	9"	14"	6"	2'-5"	2'-9"	10'-9"	8'-0"	3'-0"
24"	24"	9"	14"	6"	2'-5"	2'-9"	10'-9"	8'-0"	3'-0"
30"	15"	9"	14"	6"	2'-5"	3'-6"	13'-6"	10'-0"	3'-9"
30"	18"	9"	14"	6"	2'-5"	3'-6"	13'-6"	10'-0"	3'-9"
30"	24"	9"	14"	6"	2'-5"	3'-6"	13'-6"	10'-0"	3'-9"
30"	30"	9"	14"	6"	2'-5"	3'-6"	13'-6"	10'-0"	3'-9"
36"	15"	12"	16"	10"	3'-2"	4'-0"	15'-6"	11'-6"	4'-6"
36"	18"	12"	16"	10"	3'-2"	4'-0"	15'-6"	11'-6"	4'-6"
36"	24"	12"	16"	10"	3'-2"	4'-0"	15'-6"	11'-6"	4'-6"
36"	30"	12"	16"	10"	3'-2"	4'-0"	15'-6"	11'-6"	4'-6"
36"	36"	12"	16"	10"	3'-2"	4'-0"	15'-6"	11'-6"	4'-6"
42"	15"	12"	16"	10"	3'-2"	4'-6"	17'-6"	13'-0"	5'-3"
42"	18"	12"	16"	10"	3'-2"	4'-6"	17'-6"	13'-0"	5'-3"
42"	24"	12"	16"	10"	3'-2"	4'-6"	17'-6"	13'-0"	5'-3"
42"	30"	12"	16"	10"	3'-2"	4'-6"	17'-6"	13'-0"	5'-3"
42"	36"	12"	16"	10"	3'-2"	4'-6"	17'-6"	13'-0"	5'-3"
42"	42"	12"	16"	10"	3'-2"	4'-6"	17'-6"	13'-0"	5'-3"
48"	15"	12"	16"	10"	3'-2"	5'-0"	19'-6"	14'-6"	6'-0"
48"	18"	12"	16"	10"	3'-2"	5'-0"	19'-6"	14'-6"	6'-0"
48"	24"	12"	16"	10"	3'-2"	5'-0"	19'-6"	14'-6"	6'-0"
48"	30"	12"	16"	10"	3'-2"	5'-0"	19'-6"	14'-6"	6'-0"
48"	36"	12"	16"	10"	3'-2"	5'-0"	19'-6"	14'-6"	6'-0"
48"	42"	12"	16"	10"	3'-2"	5'-0"	19'-6"	14'-6"	6'-0"
48"	48"	12"	16"	10"	3'-2"	5'-0"	19'-6"	14'-6"	6'-0"



DEPARTMENT OF ENVIRONMENTAL RESOURCES

APPROVED BY: *St E. Wildesen*
 Ston E. Wildesen, P.E.
 Assoc. Director

DATE: 3/16/01

REVISION

JAN. 2001

STORM DRAIN
 TYPE "H" ENDWALL
 QUANTITY TABLE

SD
 33A.0

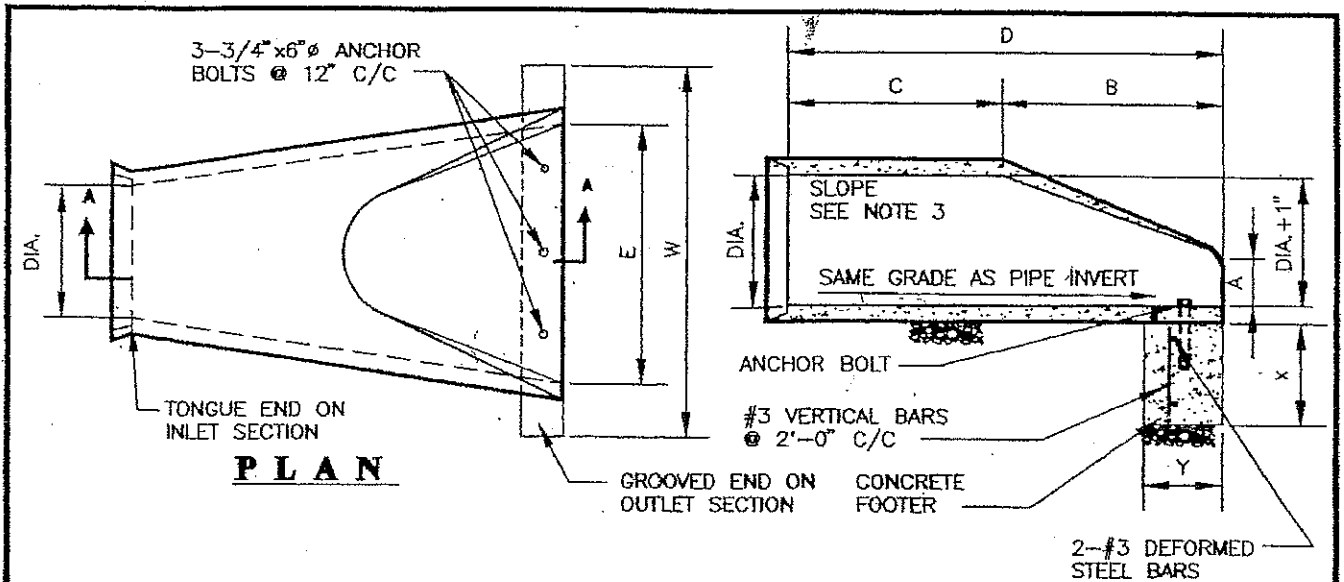

SECTION A-A

TABLE OF DIMENSIONS

PIPE DIA.	SLOPE	CONCRETE END SECTION					CONCRETE FOOTER		
		A	B	C	D	E	W	X	Y
15"	3:1	6 1/2"	2'-4"	3'-10"	6'-2"	2'-6"	3'-6"	2' MIN.	9"
18"	3:1	10 1/4"	2'-2"	4'-0"	6'-2"	3'-0"	4'-0"	2' MIN.	9"
21"	3:1	9"	3'-0"	3'-1 1/2"	6'-1 1/2"	3'-6"	4'-6"	2' MIN.	9"
24"	3:1	11"	3'-7"	2'-8"	6'-3"	4'-0"	5'-0"	2' MIN.	9"
27"	3:1	10 1/2"	4'-1 1/2"	2'-0"	6'-1 1/2"	4'-6"	5'-6"	2' MIN.	9"
30"	3:1	1'-1"	4'-5"	1'-10"	6'-3"	5'-0"	6'-0"	2' MIN.	9"
33"	3:1	1'-2"	4'-7"	2'-2"	6'-9"	5'-6"	6'-6"	2' MIN.	9"
36"	3:1	1'-3 1/2"	5'-3"	3'-1"	8'-1 1/2"	6'-0"	7'-3"	2' MIN.	9"
42"	3:1	1'-9 1/4"	5'-5"	2'-10"	8'-3"	6'-6"	7'-9"	2' MIN.	9"
48"	3:1	2'-1"	6'-0"	2'-2"	8'-2"	7'-0"	8'-6"	2' MIN.	12"
54"	2.4:1	2'-5"	5'-2"	2'-10"	8'-0"	7'-6"	9'-0"	2' MIN.	12"
60"	2:1	2'-7"	4'-11"	3'-8 1/2"	8'-7 1/2"	8'-0"	9'-6"	2' MIN.	12"
66"	2:1	2'-4"	6'-6"	1'-9"	8'-3"	8'-6"	10'-0"	2' MIN.	12"
72"	2:1	2'-10"	6'-6"	1'-9"	8'-3"	9'-0"	10'-9"	2' MIN.	12"

NOTES:

1. END SECTION MUST BE REINFORCED TO CONFORM WITH ASTM C-76 CLASS IV PIPE.
2. DEFORMED STEEL BARS TO BE ASTM A615 GRADE 60. CONCRETE $f_c' = 4,000$ psi @ 28 DAYS.
3. INVERT ELEVATION TO BE AT THE PIPE END OF THE STANDARD END SECTION ELEVATIONS TO BE NOTED ON CONSTRUCTION PLANS.
4. CONCRETE FOOTER SHALL ALWAYS BE USED WHEN SD 34.0 IS SPECIFIED ON THE PLAN. COST OF CONCRETE FOOTER TO BE INCLUDED IN THE PRICE OF END SECTION.
5. USE EPOXY BONDING AGENT TO FILL A VOID OF ANCHOR BOLTS.
6. 6" THICK BEDDING OF NO. 57 AGGREGATE ON FIRM SUBGRADE
7. PROVIDE RAILING FENCE WHEN PIPE SIZE IS 42" OR GREATER.

 <p style="text-align: center;">DEPARTMENT OF ENVIRONMENTAL RESOURCES</p> <p style="text-align: center;">APPROVED BY:</p> <p style="text-align: center;"><i>Ston E. Wildesen</i> DATE: 3/16/01</p> <p style="text-align: center;">Ston E. Wildesen, P.E. Assoc. Director</p>	REVISION	STORM DRAIN PRECAST CONCRETE END SECTION ROUND PIPE	SD 34.0
	JAN. 2001		

RIP RAP CHANNEL

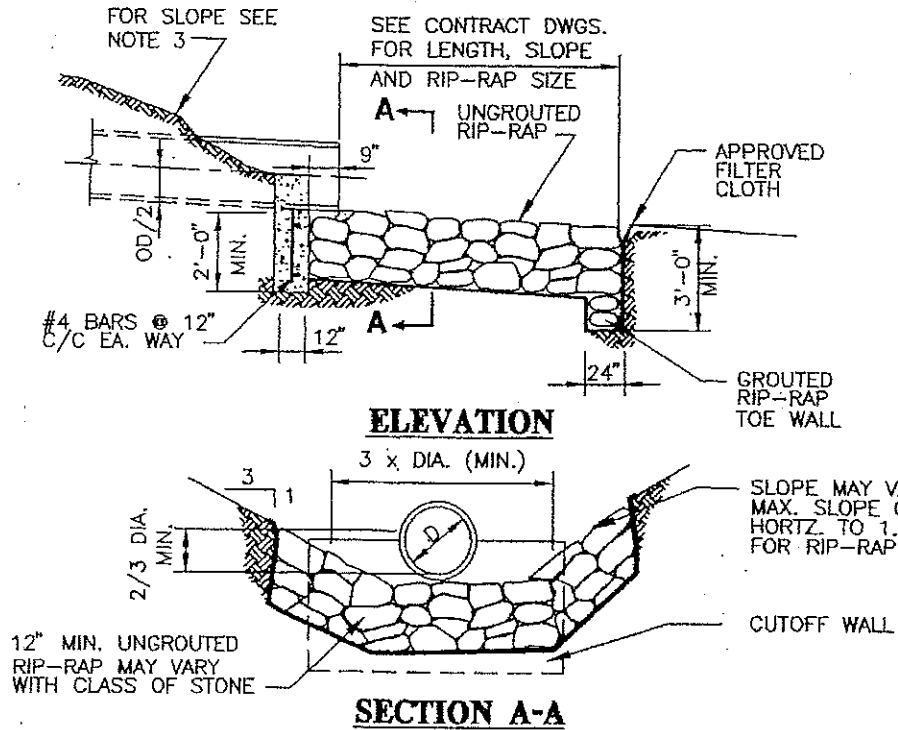

CONCRETE CHANNEL

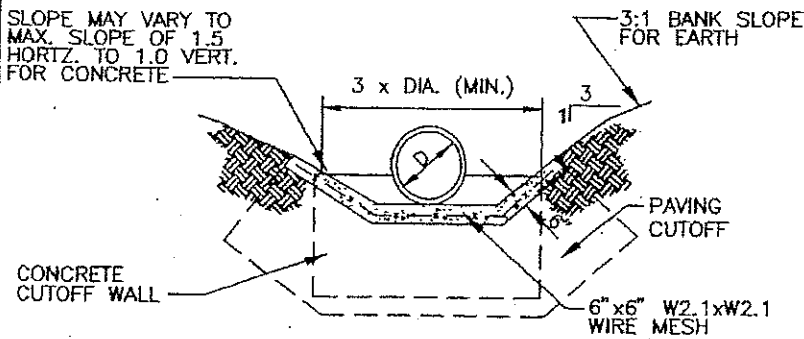
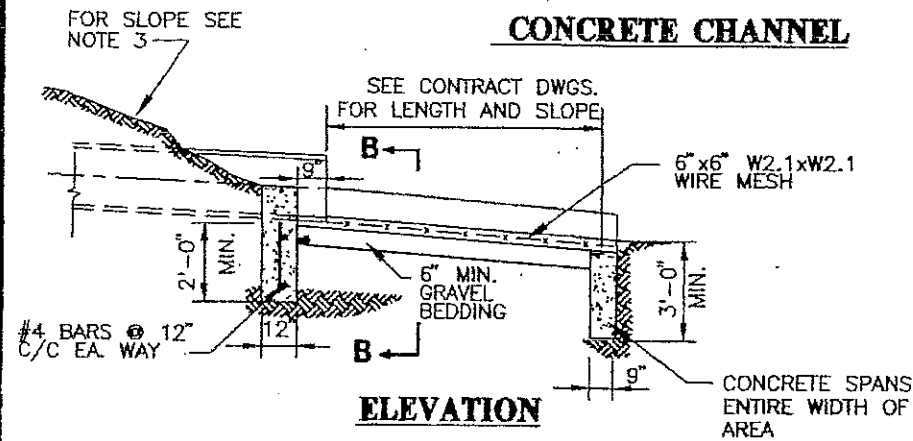

NOTES:

1. PAVING TO BE USED ONLY WHERE DIRECTED OR SHOWN. WHEN CONCRETE PAVING IS USED WIRE MESH SHALL BE EXTENDED DOWN INTO CUTOFF WALL AT LOWER END OF PAVEMENT.
2. CONCRTE STRENGTH $f_c' = 4,000$ psi @ 28 DAYS AND SHALL BE AIR ENTRAINED. ALL DEFORMED BARS SHALL BE ASTM A 615 GRADE 60.
3. THE SLOPE BEHIND THE OUTFALL SHALL BE AS PER APPROVED PLAN AND NO GREATER THAN 3:1.



DEPARTMENT OF
ENVIRONMENTAL RESOURCES

APPROVED BY:
Stan E. Wildesen
Stan E. Wildesen, P.E.
Assoc. Director

DATE:
3/16/01

REVISION

JAN. 2001

**STORM DRAIN
CUTOFF WALL AND
OUTFALL DETAIL**

**SD
35.0**

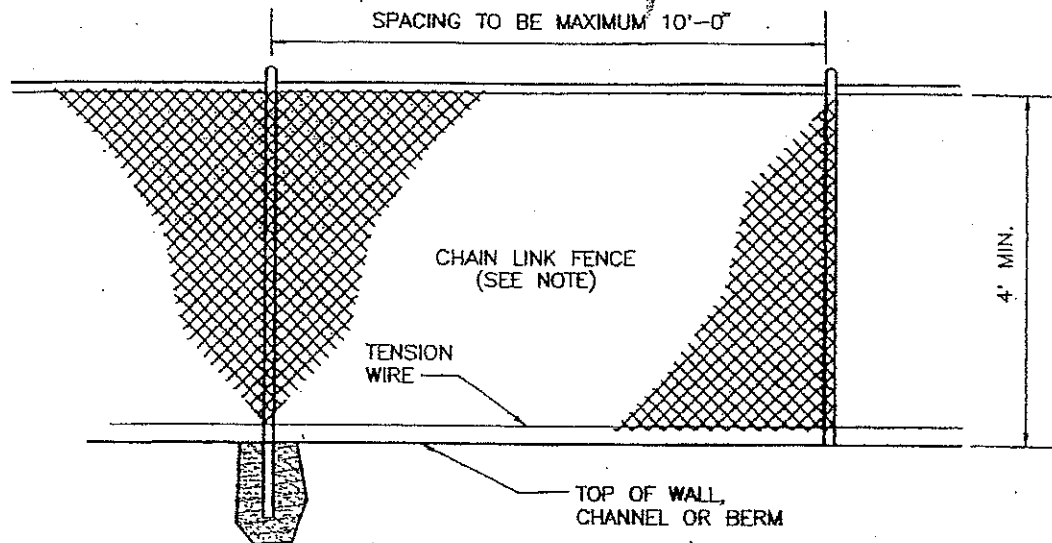

CHAIN LINK FENCE DETAIL

NOTE: REFER TO PLANS AND SPECIFICATIONS FOR GATE INFORMATION

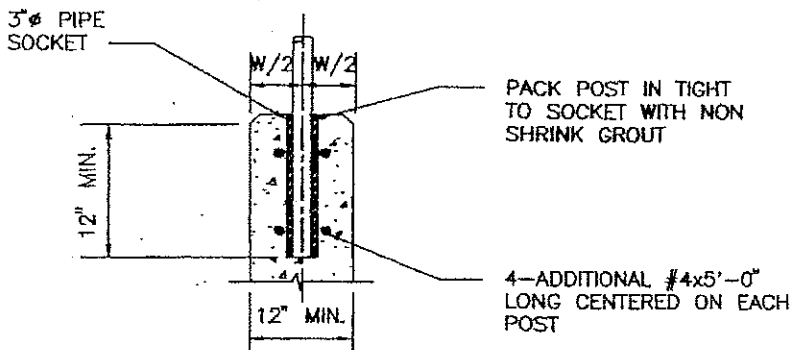

POST INSTALLATION WALL

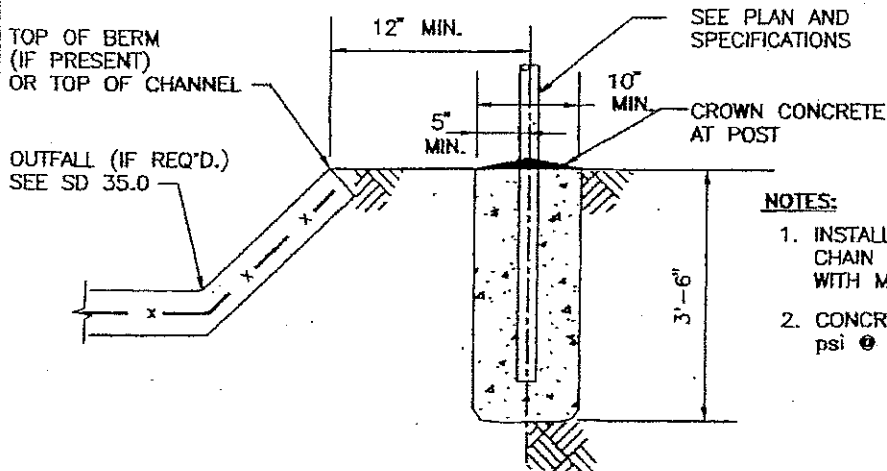

NOTES:

1. INSTALLATION AND SPECIFICATION OF CHAIN LINK FENCE SHALL BE IN COMPLIANCE WITH MANUFACTURER'S MANUAL.
2. CONCRETE STRENGTH SHALL BE $f_c' = 4,000$ psi @ 28 DAYS WITH AIR ENTRAINED.

POST INSTALLATION ALONG CHANNEL



DEPARTMENT OF ENVIRONMENTAL RESOURCES

APPROVED BY: *Stan E. Wildesen*
 Stan E. Wildesen, P.E.
 Assoc. Director

DATE: 3/16/01

REVISION

JAN, 2001

STORM DRAIN
 CHAIN LINK
 FENCE DETAIL

SD
 40.0

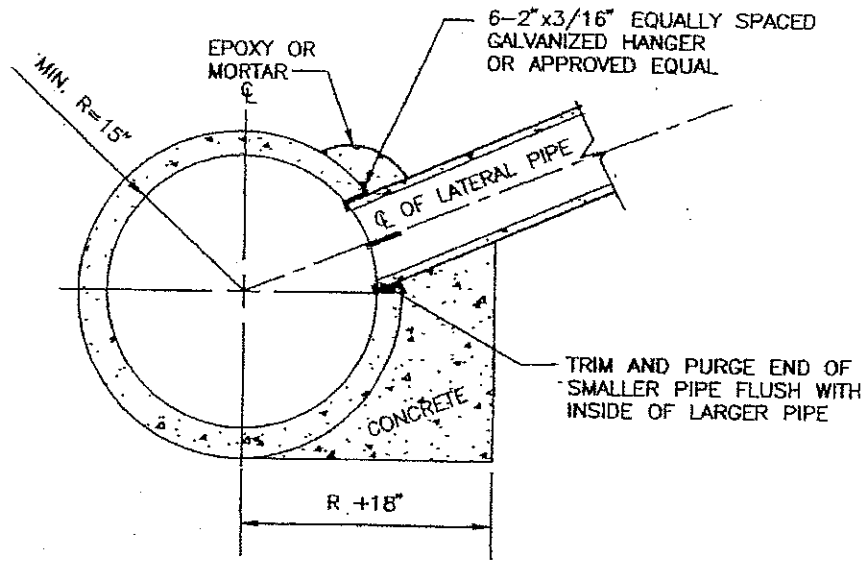
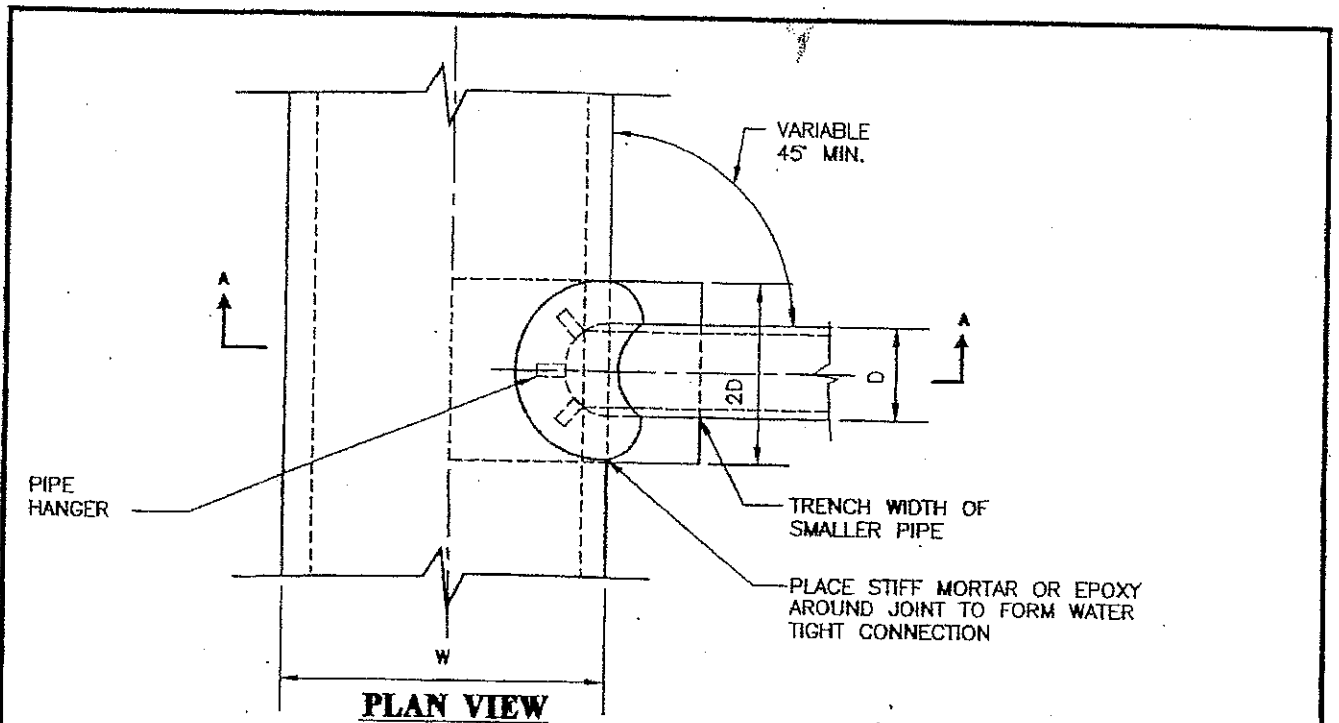

SECTION A-A

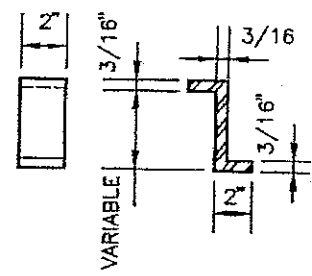

NOTES

1. OPENING MUST BE MADE WITH APPROPRIATE EQUIPMENT. ANY CRACKING OR DAMAGE OF PIPE WILL REQUIRE DETERMINATION OF ACCEPTANCE BY THE INSPECTOR.
2. CONCRETE FILLING TO BE $f_c = 3,500$ psi OR HIGHER IN STRENGTH.



DEPARTMENT OF ENVIRONMENTAL RESOURCES

APPROVED BY: *St. E. Wilder* DATE: 3/16/01

Stan E. Wilder, P.E.
Assoc. Director

REVISION
JAN. 2001

STORM DRAIN FIELD CONNECTION FOR RCP

SD 50.0

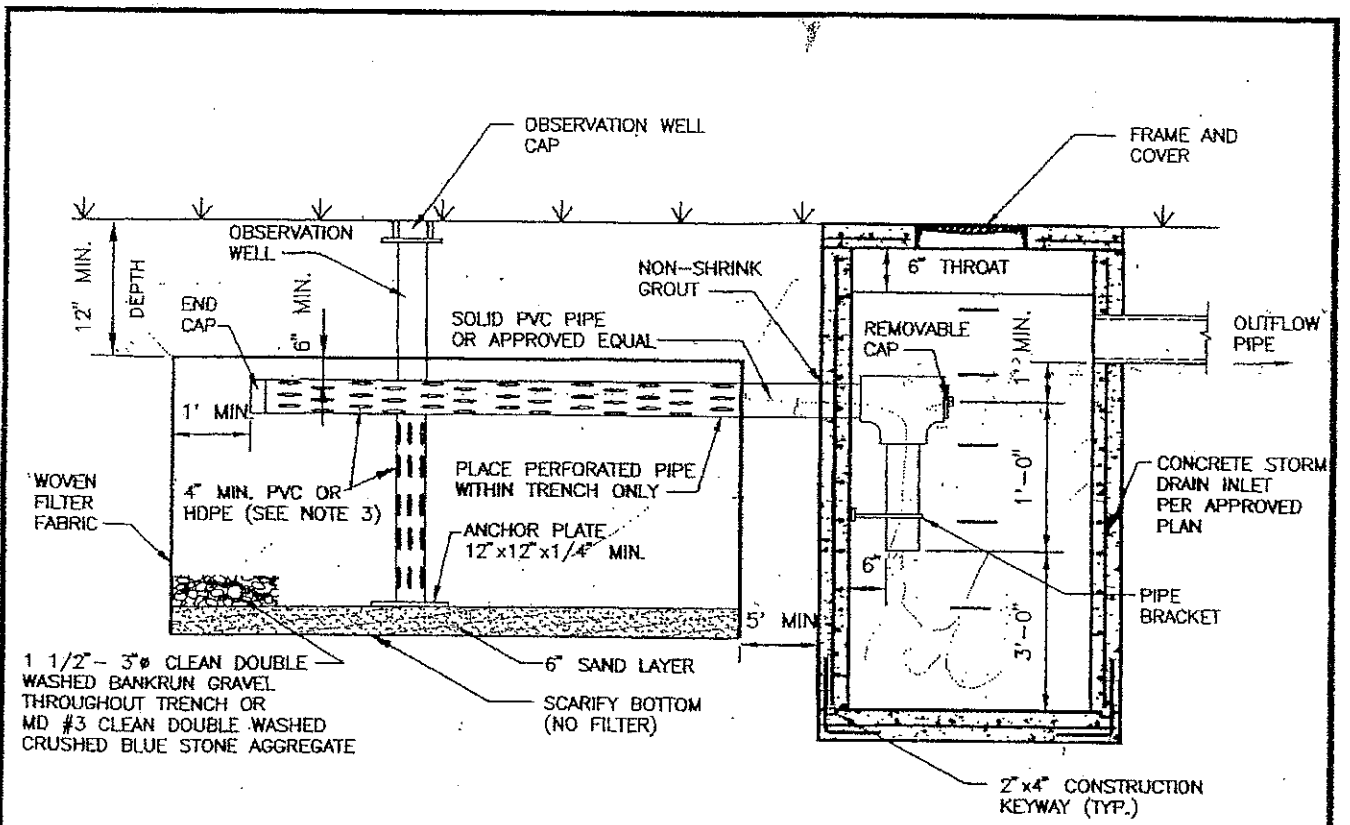

ELEVATION

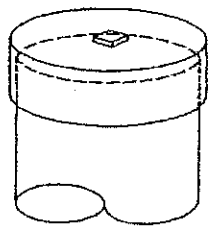

THREADED WELL CAP (CLOSED)

NOTES:

1. FILTER CLOTH TO BE PLACED AT ALL SIDES, EXCEPT THE BOTTOM.
2. SET WELL CAP ABOVE GRADE IN UNIMPROVED AREAS.
3. PIPE SIZES SHALL BE IN ACCORDANCE WITH THE APPROVED PLAN.



DEPARTMENT OF ENVIRONMENTAL RESOURCES

APPROVED BY: *Ston E. Widesen* DATE: 3/16/01
 Ston E. Widesen, P.E.
 Assoc. Director

REVISION

JAN. 2001

STORM DRAIN INFILTRATION SYSTEM DETAIL

SD 70.0

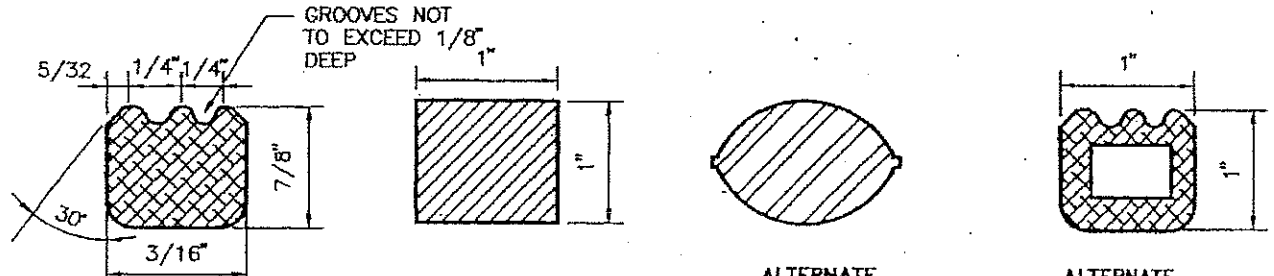
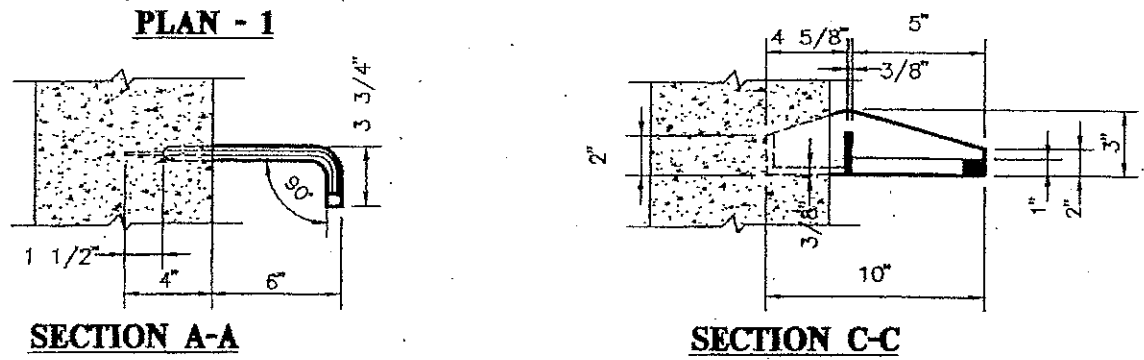
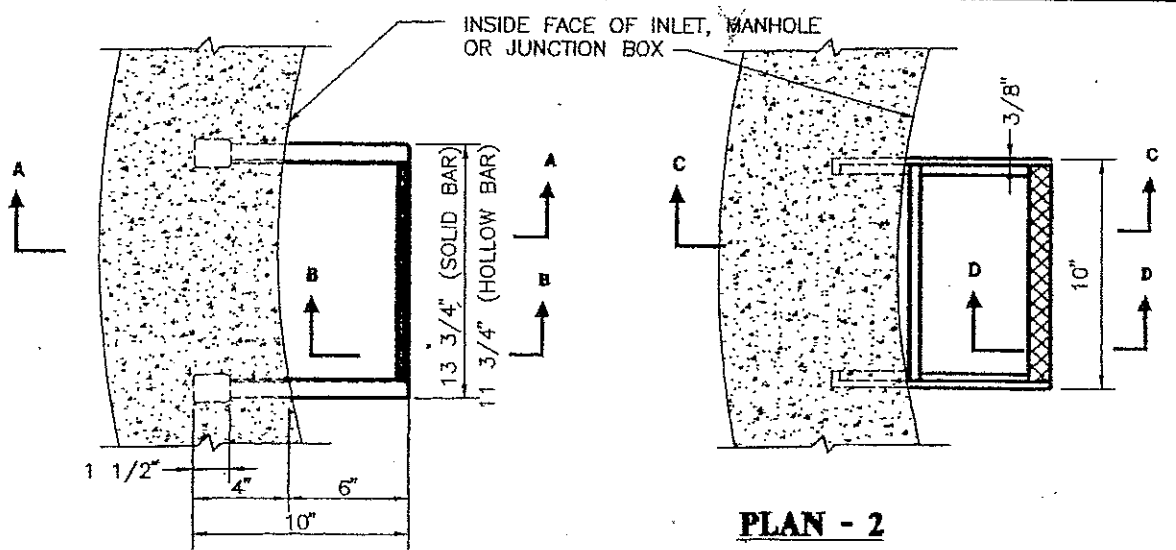

① ALUMINUM ALLOY (SOLID BAR)

② CAST IRON

③ STEEL

④ ALUMINUM ALLOY (HOLLOW BAR)

- NOTES:
- METAL LADDER RUNGS ARE TO BE USED IN INLETS, MANHOLES AND JUNCTION BOXES OVER 3' IN DEPTH OR AS DIRECTED BY THE ENGINEER, USED EITHER WITH BRICK OR CONCRETE CONSTRUCTION. (WHERE BRICK CONSTRUCTION IS EMPLOYED, THE MORTAR JOINTS SHALL BE ADJUSTED TO ACCOMMODATE LADDER RUNGS) METAL LADDER RUNGS MAY BE COMPRISED OF ONE OF THE FOLLOWING:
 - ALUMINUM ALLOY—SHALL CONFORM TO ASTM DESIGNATION B221 ALLOY 6061-T6. THAT PORTION EMBEDDED IN THE STRUCTURE SHALL BE COATED WITH ZINC CHROMATE OR APPROVED EQUIVALENT.
 - CAST IRON SHALL CONFORM TO ASTM A48 CLASS 308.
 - STEEL SHALL CONFORM TO ASTM A615 GRADE 48, GALVANIZED AFTER FABRICATION AS PER ASTM A153.
 - ALUMINUM ALLOY—SHALL CONFORM TO ASTM DESIGNATION B221 ALLOY 6061-T6. THAT PORTION EMBEDDED IN THE STRUCTURE SHALL BE COATED WITH ZINC CHROMATE OR APPROVED EQUIVALENT.
 - ALL STEPS TO BE 12" ± 1" CENTER TO CENTER.
 - BOTTOM STEP TO BE 5" MIN. AND 16 1/2" MAX. ABOVE WORKING LEVEL.
 - STEPS SHALL BE SET SUCH THAT THEY ARE IN VERTICAL ALIGNMENT WITH MANHOLE ACCESS OPENING AND ALIGN WITH BENCH.



DEPARTMENT OF ENVIRONMENTAL RESOURCES

APPROVED BY: *Stan E. Wildesen* DATE: 3/16/01

Stan E. Wildesen, P.E. Assoc. Director

REVISION
JAN. 2001

STORM DRAIN
MANHOLE AND INLET
STEPS IN CHANNELS

SD
80.0

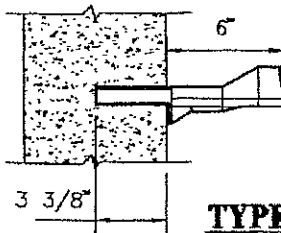
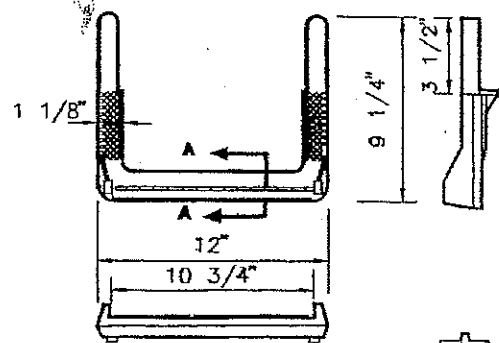
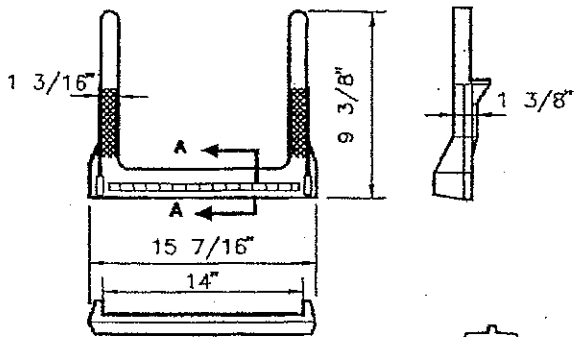

SECTION A-A

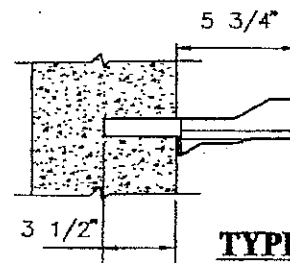

SECTION A-A

TYPE "A"

TYPE "B"

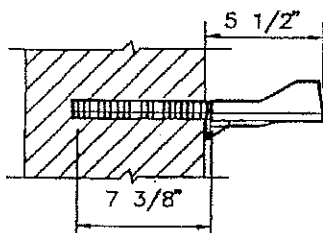
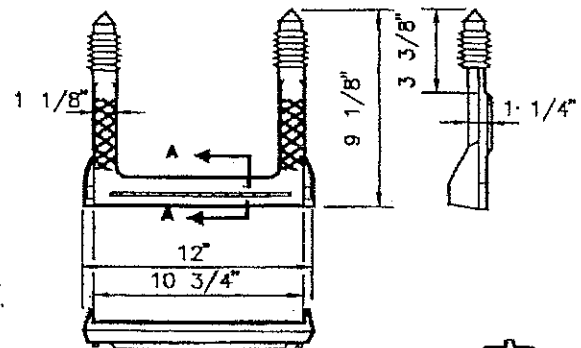
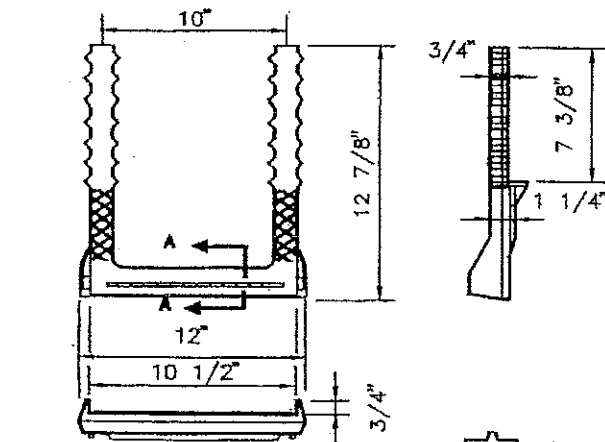

SECTION A-A

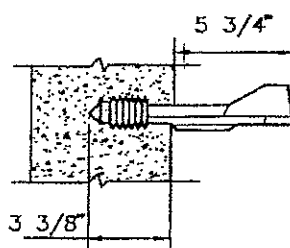

SECTION A-A

TYPE "C"

TYPE "D"

NOTES:

1. TYPES "A" AND "B" ARE TO BE DRIVEN INTO RECEPTACLES THAT ARE CAST INTO WALL.
2. TYPE "C" IS FOR BRICK OR BLOCK INSTALLATIONS.
3. TYPE "D" IS PRESS FITTED INTO PREFORMED CONCRETE HOLES.
4. LADDER RUNGS ARE TO BE USED IN INLETS, MANHOLES AND JUNCTION BOXES OVER 3 FEET IN DEPTH OR AS DIRECTED BY ENGINEER, USED EITHER WITH BRICK OR CONCRETE CONSTRUCTION. (WHERE BRICK CONSTRUCTION IS EMPLOYED, MORTAR JOINTS SHALL BE ADJUSTED.
5. COPOLYMER POLYPROPYLENE ENCAPSULATED 1/2" Ø STEEL REINFORCEMENT BAR STEEL SHALL CONFORM TO ASTM A615 GRADE 60 AND SHALL BE CERTIFIED BY MANUFACTURER TO CONFORM TO ASTM 4101 AND HAVE A MINIMUM EXPOSED THICKNESS OF 1/8".
6. SECTION A-A SHOWS 1/2" Ø STEEL REINFORCEMENT BAR.
7. INSTALLATION SHALL CONFORM TO MANUFACTURER'S RECOMMENDATIONS.



DEPARTMENT OF ENVIRONMENTAL RESOURCES

APPROVED BY:

Stan E. Wildesen
 Stan E. Wildesen, P.E.
 Assoc. Director

DATE:

3/16/01

REVISION

JAN 2001

STORM DRAIN
 COPOLYMER POLYPROPYLENE
 STEEL ENCAPSULATED
 LADDER RUNG

SD
 81.0

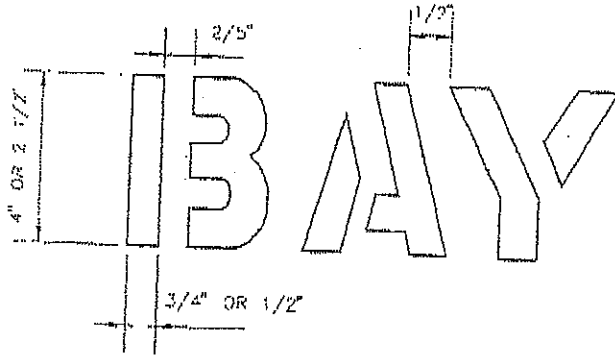

SAMPLE
NOT TO SCALE

NOTE

1. THE WORDS "CHESAPEAKE BAY DRAINAGE" AND "DON'T DUMP" MUST BE PLACED ON THE ARMOR CHANNEL OF THE COUNTY'S PUBLIC AND PRIVATE STORM DRAIN INLETS.
2. GRAY RUST-PROOFING NONTOXIC PAINT FOR THE BACKGROUND.
3. BLUE ENAMEL SPRAY NONTOXIC PAINT FOR LETTERS.
4. FOR OTHER SPECIFICATIONS, REFER TO MANUFACTURER'S INSTRUCTIONS.



DEPARTMENT OF ENVIRONMENTAL RESOURCES

APPROVED BY:

Stan L. Winkler, P.E.
Assoc. Director

DATE:

REVISION

JAN. 2001

STORM DRAIN
SIGN STENCIL

SD
82.0

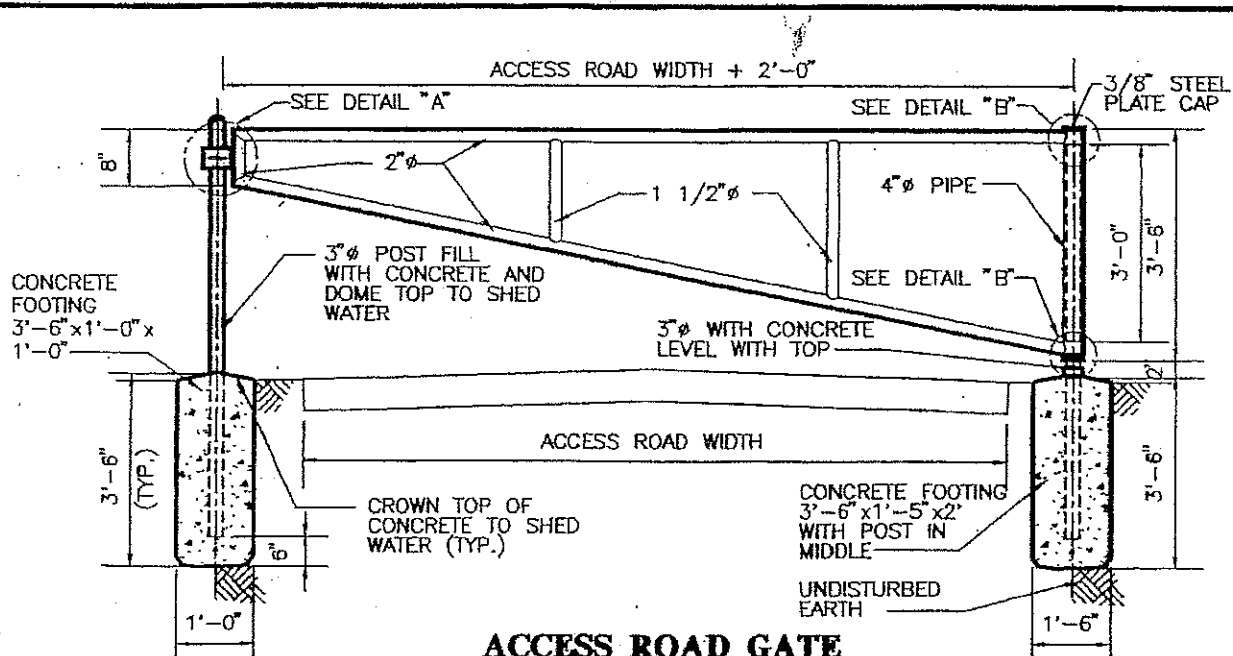

ACCESS ROAD GATE

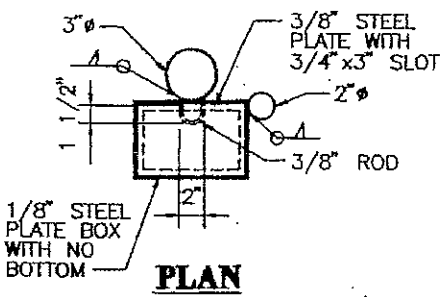

PLAN

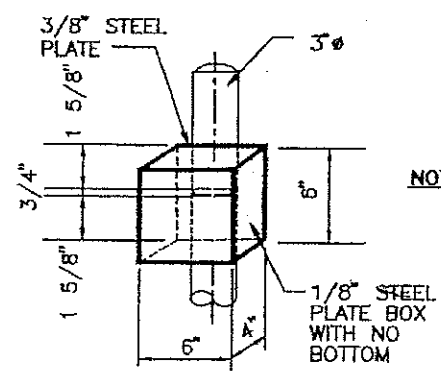

ELEVATION

DETAIL "A"

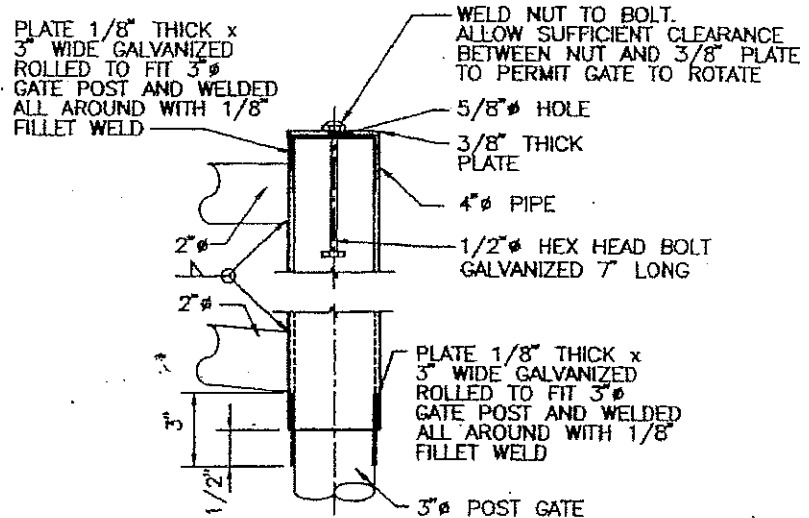

DETAIL "B"

NOTES:

1. ALL METAL USED IN THE MANUFACTURE OF THE ACCESS ROAD GATE TO BE HOT DIP GALVANIZED. ALL WELDS AND PIPE TO BE PAINTED AND TOUCHED UP IN ACCORDANCE WITH MANUFACTURES RECOMMENDATIONS.
2. ALL JOINTS TO BE WELDED ALL AROUND WITH 3/16" WELDS.
3. ALL PIPE TO BE SCHEDULE 40 STEEL. DIAMETERS SHOWN ARE NOMINAL PIPE SIZE.
4. PADLOCK WILL BE FURNISHED BY PRINCE GEORGE'S COUNTY IF IT IS IN PUBLIC PROPERTY.
5. CONTRACTOR SHALL PROVIDE AN ADDITIONAL 3" POST WITH 3/8" ROD. LOCATE TO HOLD GATE IN AN OPEN POSITION 90° FROM THAT SHOWN BELOW.
6. GATE TO SWING IN TOWARDS PRINCE GEORGE'S COUNTY PROPERTY OR EASEMENT.
7. WIDTH OF GATE NOT TO EXCEED 16 FT.
8. CONCRETE STRENGTH $f_c' = 4,000 \text{ psi} @ 28 \text{ DAYS WITH AIR ENTRAINED.}$



DEPARTMENT OF ENVIRONMENTAL RESOURCES

APPROVED BY: *[Signature]*
 Ston E. Wildesen, P.E.
 Assoc. Director

DATE: 3/16/01

REVISION
JAN 2001

STORMWATER MANAGEMENT
 ACCESS ROAD GATE

SD
 83.0

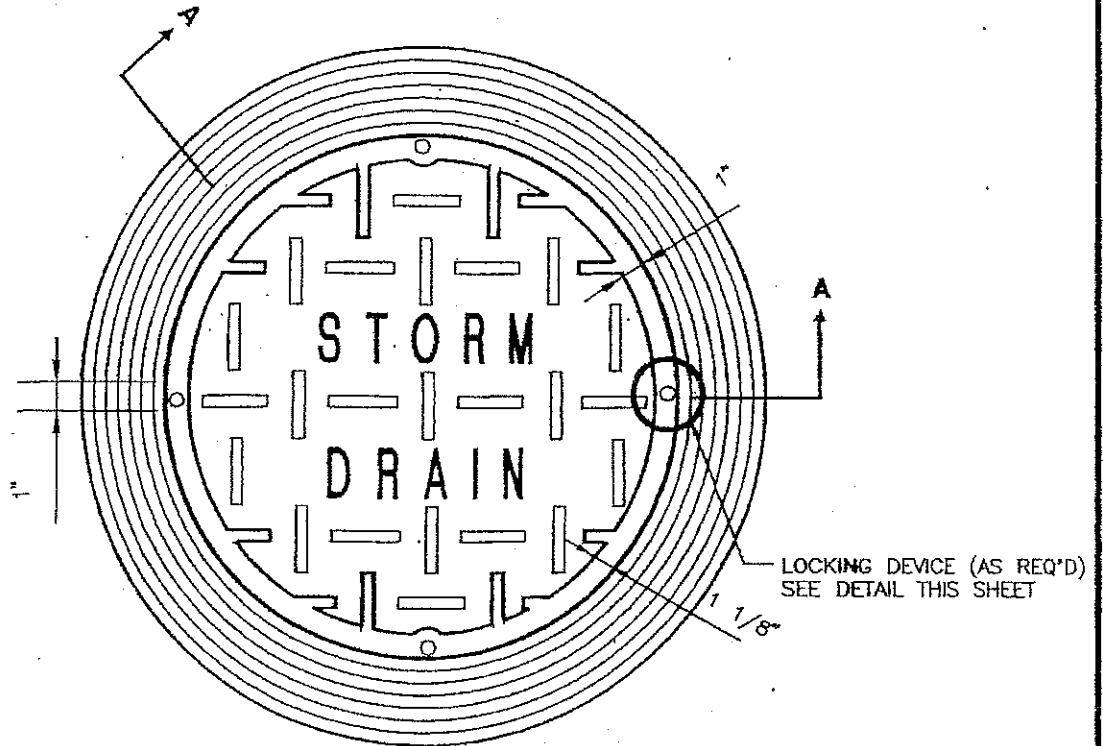

PLAN

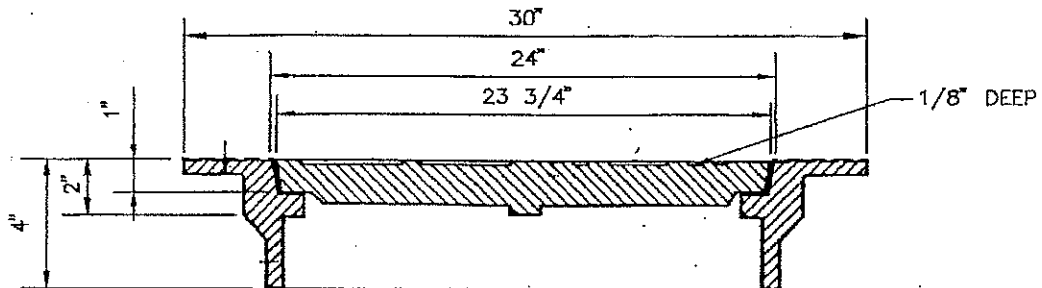

SECTION A-A

1/2"-13 NC HEX HEAD
STAINLESS STEEL (2 REQ'D.)

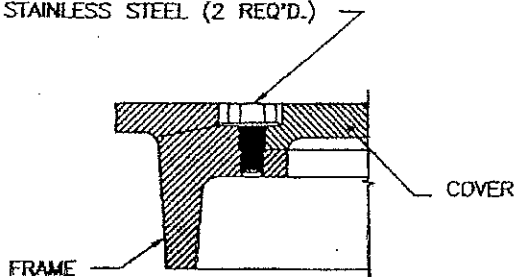

LOCKING DEVICE DETAIL
(AS REQUIRED)

NOTE:

1. THE WORDS "STORM DRAIN" SHALL BE CAST INTO THE TOP CENTER OF ALL STORM DRAIN COVERS.
2. MATERIAL OF FRAME AND COVER SHALL BE CAST IRON OR DUCTILE IRON CASTING.
3. CAST IRON SHALL CONFORM TO ASTM A48 CLASS 30 OR AASHTO M105 CLASS 30.
4. DUCTILE IRON COATING SHALL CONFORM TO ASTM A536 GRADE 65-45-12.
5. MINIMUM PROOF LOAD TEST OF 4,000 LBS. SHALL BE PERFORMED IN ACCORDANCE WITH THE LATEST VERSION OF FEDERAL SPECIFICATIONS RR-F-621.
6. PROVIDE NON-SLIP TREAD ON COVER.
7. LOCKING DEVICE AS REQUIRED AS SHOWN ON DRAWING OR APPROVED EQUAL.



DEPARTMENT OF
ENVIRONMENTAL RESOURCES

APPROVED BY:

Ston E. Wildesen DATE: *3/16/01*

Ston E. Wildesen, P.E.
Assoc. Director

REVISION

JAN. 2001

**STORM DRAIN
MANHOLE FRAME & COVER
(NON-TRAFFIC AREA)**

**SD
90.0**

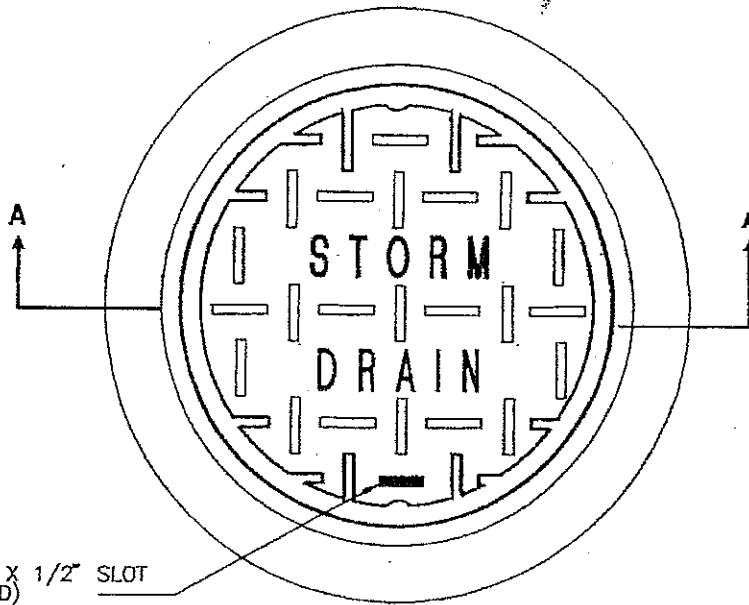

1 1/2" X 1/2" SLOT
(2 REQ.D)

PLAN

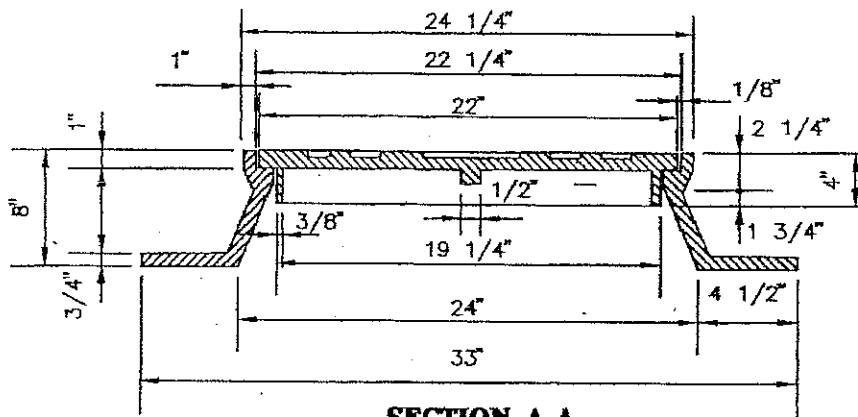

SECTION A-A

NOTE:

1. THE WORDS "STORM DRAIN" SHALL BE CAST INTO THE TOP CENTER OF ALL STORM DRAIN COVERS.
2. MATERIAL OF FRAME AND COVER SHALL BE CAST IRON OR DUCTILE IRON CASTING.
3. CAST IRON SHALL CONFORM TO ASTM A48 CLASS 30 OR AASHTO M105 CLASS 30.
4. DUCTILE IRON COATING SHALL CONFORM TO ASTM A536 GRADE 65-45-12.
5. FRAME AND COVER SHALL BE HEAVY DUTY TO CONFORM WITH AASHTO H20/HS20 LOADING CONDITIONS (16,000 LBS. WHEEL LOADS).
6. MINIMUM PROOF LOAD TEST OF 25,000 LBS. SHALL BE PERFORMED IN ACCORDANCE WITH THE LATEST VERSION OF FEDERAL SPECIFICATIONS RR-F-621.



DEPARTMENT OF ENVIRONMENTAL RESOURCES

APPROVED BY: *Ston E. Wildesen*
Ston E. Wildesen, P.E.
Assoc. Director

DATE: 3/16/01

REVISION
JAN. 2001

STORM DRAIN
MANHOLE
RING AND COVER
(TRAFFIC AREA)

SD
90.1

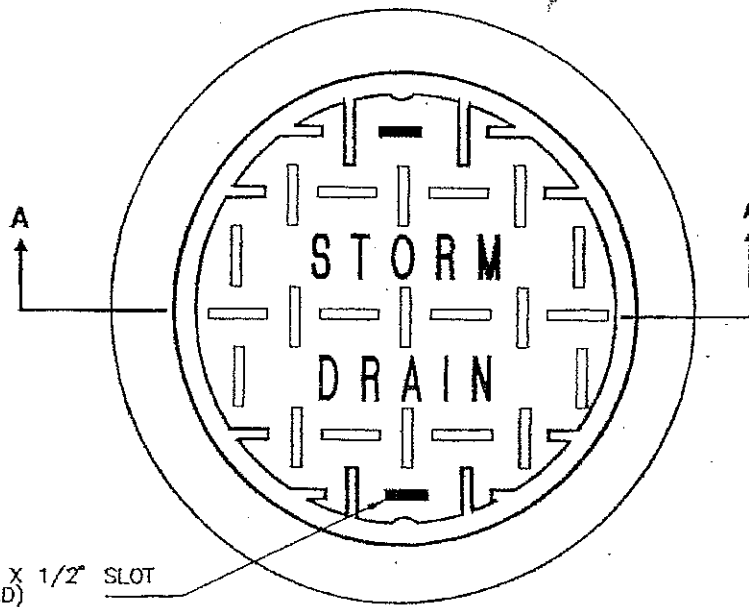

1 1/2" X 1/2" SLOT
(2 REQ.D)

PLAN

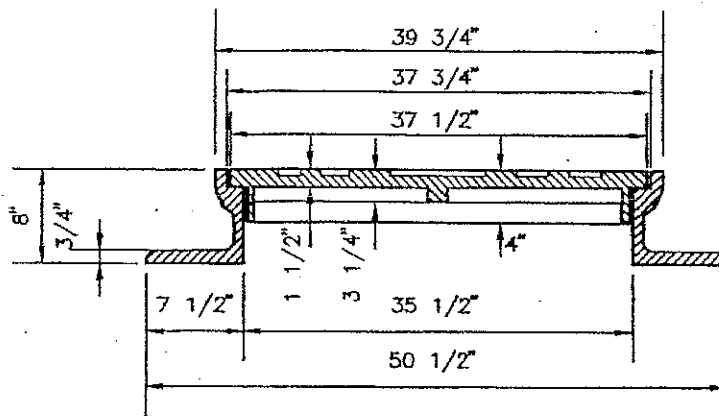

SECTION A-A

NOTE:

1. THE WORDS "STORM DRAIN" SHALL BE CAST INTO THE TOP CENTER OF ALL STORM DRAIN COVERS.
2. MATERIAL OF FRAME AND COVER SHALL BE CAST IRON OR DUCTILE IRON CASTING.
3. CAST IRON SHALL CONFORM TO ASTM A48 CLASS 30 OR AASHTO M105 CLASS 30.
4. DUCTILE IRON COATING SHALL CONFORM TO ASTM A536 GRADE 65-45-12.
5. FRAME AND COVER SHALL BE HEAVY DUTY TO CONFORM WITH AASHTO H20/HS20 LOADING CONDITIONS (16,000 LBS. WHEEL LOADS).
6. MINIMUM PROOF LOAD TEST OF 25,000 LBS. SHALL BE PERFORMED IN ACCORDANCE WITH THE LATEST VERSION OF FEDERAL SPECIFICATIONS RR-F-621.



DEPARTMENT OF ENVIRONMENTAL RESOURCES

APPROVED BY:
Star E. Wildesen
Star E. Wildesen, P.E.
Assoc. Director

DATE:
3/16/01

REVISION

JAN. 2001

STORM DRAIN
FRAME AND COVER FOR
6' AND 7' DIA. MANHOLES
(TRAFFIC AREA)

SD
90.2

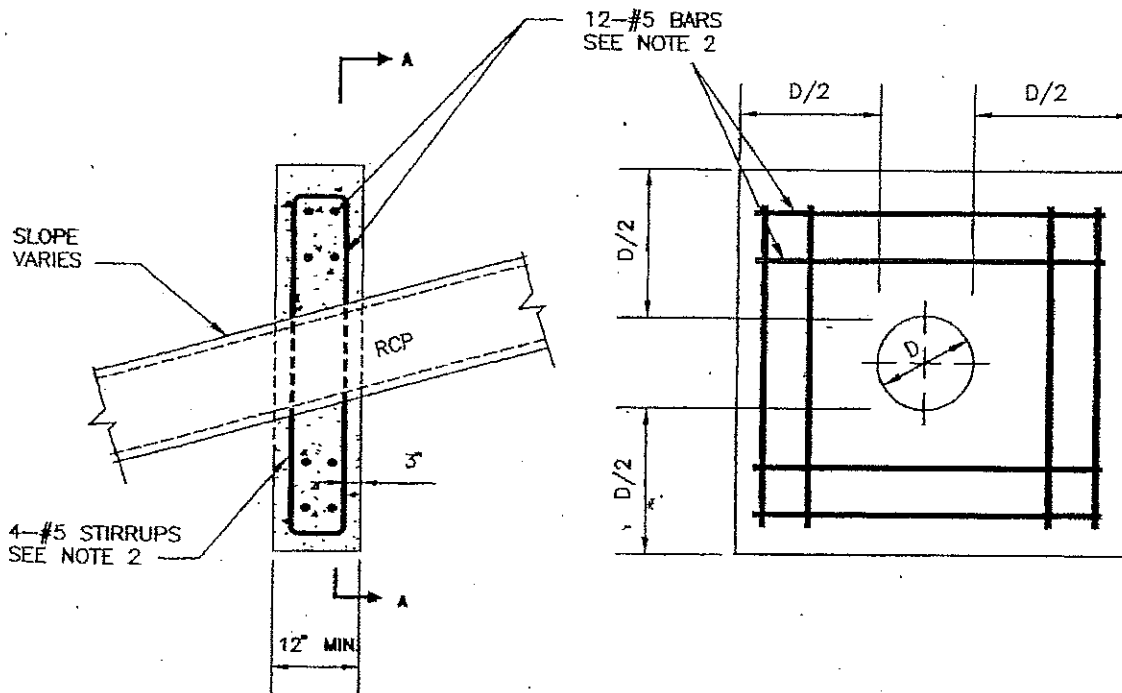

ELEVATION

SECTION A-A

NOTES:

1. $f_c' = 4000 \text{ psi}$ @ 28 DAYS.
2. ALL REINFORCING STEEL TO BE ASTM A615 GRADE 60.
3. CARRY ALL BEARING SURFACES TO FIRM SUBGRADE. PLACE CONCRETE ANCHOR AGAINST DOWNGRADE SIDE OF BELL.
4.

PIPE SLOPE	MAX. DISTANCE OF ANCHOR C.C.
20%-34%	36'
35%-50%	24'
50% OR MORE	16'
5. USE EPOXY ADHESIVE TO FILL AREA BETWEEN PIPE AND ANCHOR.
6. 2" MINIMUM CONCRETE CLEARANCE.
7. 1/2" REINFORCEMENT BAR CLEARANCE.



DEPARTMENT OF ENVIRONMENTAL RESOURCES

APPROVED BY: *Stan E. Wildesen* DATE: *3/16/01*
 Stan E. Wildesen, P.E.
 Assoc. Director

REVISION

JAN. 2001

STORM DRAIN
 CONCRETE ANCHOR FOR
 15" TO 30" PIPES

SD
 100.0

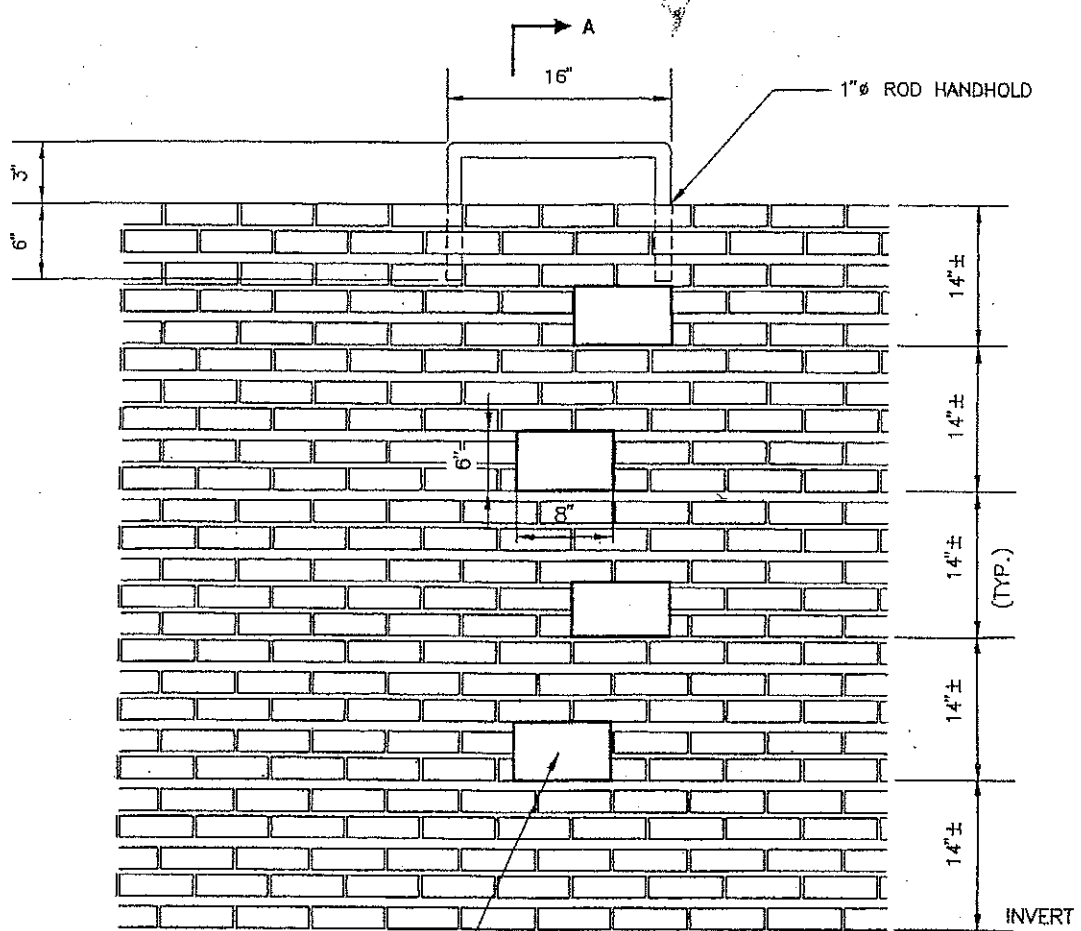

PROVIDE STEP BY LEAVING BRICKS OUT OF CHANNEL AS SHOWN. STEPS TO BE 4" MINIMUM DEPTH AND PARGE 4" THICKNESS TO SEAL STEP USING NON-SHRINK CONCRETE OR MORTAR

ELEVATION

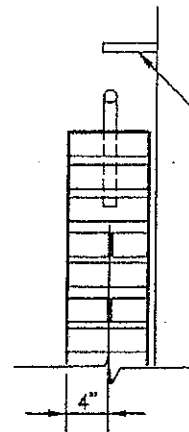

SECTION A-A

NOTE:

FOR CHANNELS LESS THAN 8" THICK PROVIDE STANDARD MANHOLE STEP 6" MAXIMUM ABOVE TOP OF CHANNEL



DEPARTMENT OF ENVIRONMENTAL RESOURCES

APPROVED BY: *Ston E. Wildesen*
 DATE: 3/16/01
 Ston E. Wildesen, P.E.
 Assoc. Director

REVISION

JAN. 2001

STORM DRAIN
 MANHOLE AND INLET
 STEPS IN CHANNELS

SD
 110.0

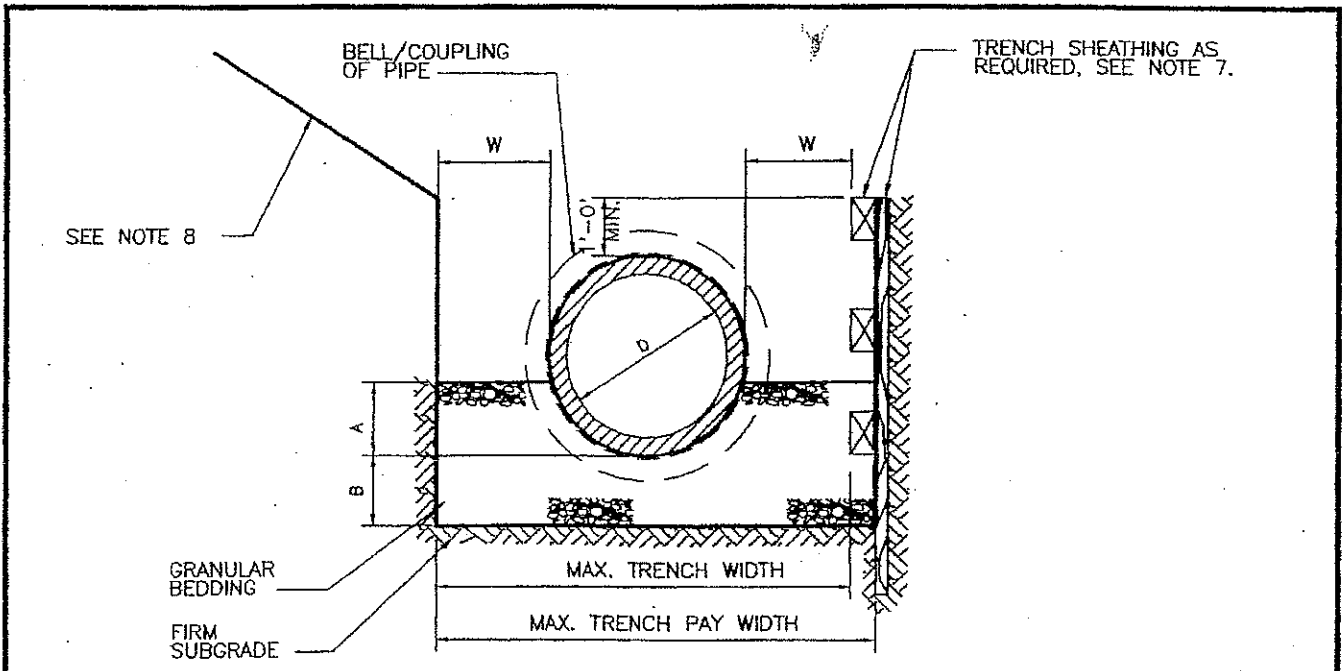

ELEVATION

DIMENSIONS			
D	A	W	B
15"	5"	8"	6"
16" & 18"	6"	8"	6"
20" & 21"	7"	8"	6"
24"	8"	12"	6"
27"	8"	12"	6"
30"	9"	12"	6"
33"	10"	15"	6"
36"	10"	15"	6"
42"	13"	15"	6"
48"	15"	18"	6"
54"	16"	18"	6"
60"	18"	18"	6"
66"	21"	18"	6"
72"	21"	18"	6"
78"	23"	18"	6"
84"	25"	18"	6"
90"	26"	18"	6"
96"	28"	18"	12"
102"	30"	18"	12"
108"	32"	18"	12"
114"	34"	24"	12"
120"	36"	24"	12"

NOTES:

1. THIS DETAIL APPLIES TO RCP STORM DRAIN PIPE ONLY.
2. WHERE SPECIFICALLY REQUIRED, $f_c' = 3,000$ psi @ 28 DAYS CONCRETE AND SADDLE BLOCKS SHALL BE USED IN LIEU OF THE GRAVEL CRADLE.
3. BEDDING MATERIAL FOR CIRCULAR AND ELLIPTICAL PIPES SHALL BE IN ACCORDANCE WITH DEPARTMENT OF ENVIRONMENTAL RESOURCES STORMWATER MANAGEMENT STANDARDS AND SPECIFICATIONS.
4. MAXIMUM CLEAR TRENCH WIDTH SHALL BE $2W$ PLUS THE OUTSIDE DIAMETER OF THE PIPE.
5. THIS PIPE BEDDING DETAIL IS NOT FOR PIPES AND STRUCTURES WITHIN AN STORM MANAGEMENT POND EMBANKMENT.
6. UNLESS OTHERWISE NOTED ON DRAWING, ALL CONSTRUCTION METHODS, PROCEDURES MUST BE IN COMPLIANCE WITH DEPARTMENT OF ENVIRONMENTAL RESOURCES, STORMWATER MANAGEMENT STANDARDS AND SPECIFICATIONS.
7. SHEETING, SHORING AND BRACING SHALL MEET REQUIREMENTS OF MOSHA AND DESIGNED BY THE ENGINEER PRIOR TO APPROVAL.
8. PROVIDE MAXIMUM 4' DEEP VERTICAL SLOPE FOR TRENCH AND USE 1:1 SLOPE ABOVE THE MAXIMUM DEPTH.



DEPARTMENT OF ENVIRONMENTAL RESOURCES

APPROVED BY: *Ston E. Wilden* DATE: 3/16/01
 Ston E. Wilden, P.E.
 Assoc. Director

REVISION
JAN. 2001

STORM DRAIN BEDDING AND TRENCH WIDTHS FOR PIPE

SD 130.0

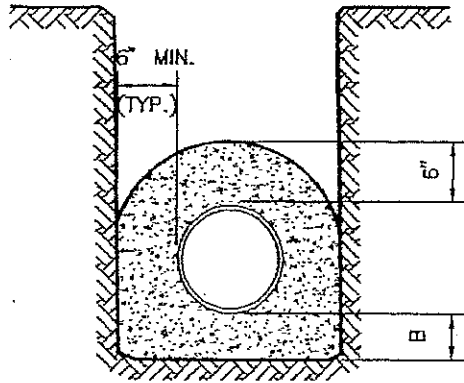

ENCASEMENT DETAIL

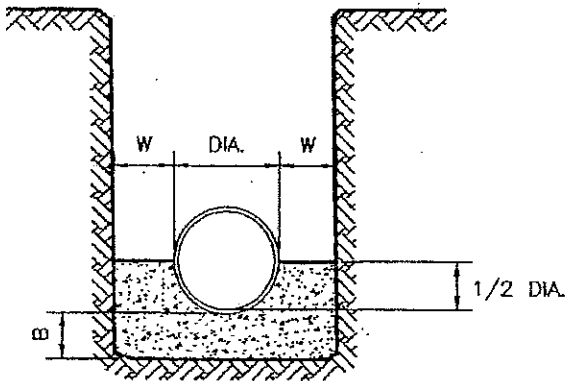

LOW CRADLE DETAIL

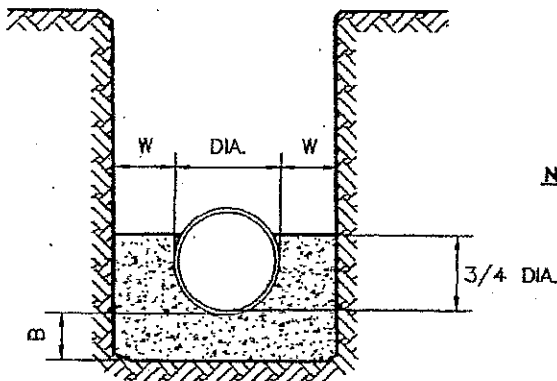

HIGH CRADLE DETAIL

DIMENSIONS		
D	W	B
15"	8"	SEE NOTE 1
16" & 18"	8"	
20" & 21"	8"	
24"	12"	
27"	12"	6"
30"	12"	6"
33"	15"	6"
36"	15"	6"
42"	15"	6"
48"	18"	6"
54"	18"	6"
60"	18"	6"
66"	18"	6"
72"	18"	6"
78"	18"	6"
84"	18"	6"
90"	18"	6"
96"	18"	12"
102"	18"	12"
108"	18"	12"
114"	24"	12"
120"	24"	12"

NOTES:

1. 3" MIN. FOR PIPES 24" DIAMETER AND SMALLER
SEE TABLE FOR PIPES LARGER THAN 24" DIAMETER
2. PLACE TRENCH SHORING AS REQUIRED.
3. POUR CONCRETE AGAINST UNDISTURBED
EARTH. REMOVE SHEETING BEFORE POURING
OR LEAVE LOWER PORTION OF SHEETING
IN PLACE. ALL CONCRETE SHALL HAVE
fc' = 3,500 psi @ 28 DAYS.



DEPARTMENT OF
ENVIRONMENTAL RESOURCES

APPROVED BY:
Ston E. Widesen
Ston E. Widesen, P.E.
Assoc. Director

DATE:
3/16/01

REVISION

JAN. 2001

STORM DRAIN
CONCRETE & ENCASEMENT
CRADLE DETAILS

SD
150.0

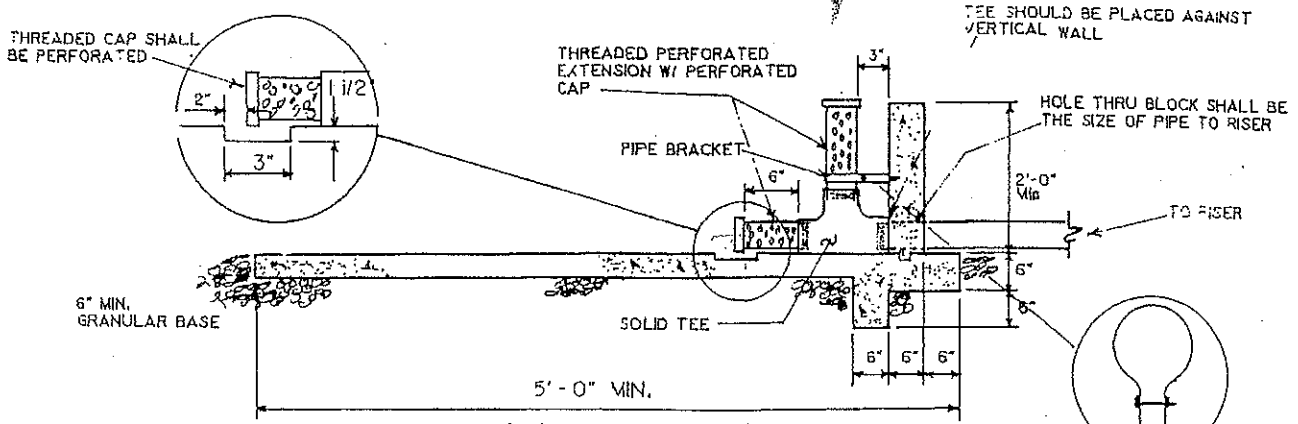

ELEVATION

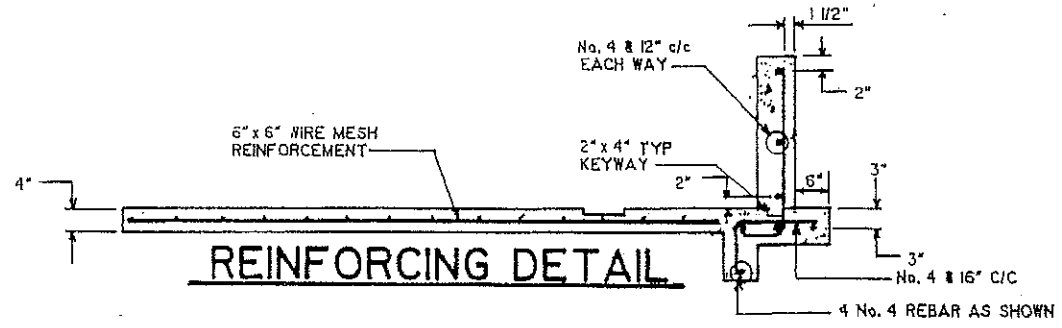
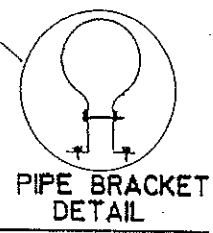

REINFORCING DETAIL

NOTES:

1. TOTAL AREA OF PERFORATIONS = TWICE (2x) THE CROSS SECTIONAL AREA OF PIPE
2. 1c' = 4000 PSI FOR CONC @ 28 DAYS
3. ALL STEEL TO BE ASTM A 615 GRADE 60.
4. PIPE BRACKET SHALL BE GALVANIZED AND COATED WITH BATTLESHIP GREY PAINT (SEE NOTE 5 SD 10.0)
5. ALL EXPOSED EDGES TO HAVE 3/4" x 3/4" CHAMFER OR AS DIRECTED
6. OTHER OPTIONS SHOULD BE APPROVED BY Prince George's County Department Of Environmental Resources, Watershed Protection Branch.

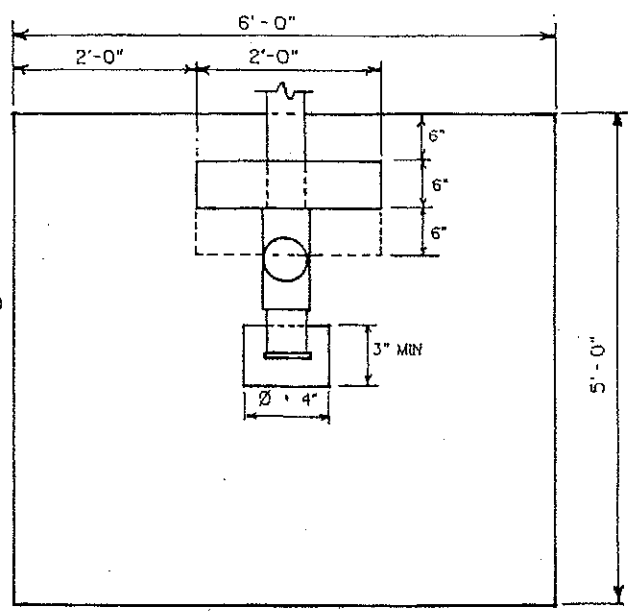

PLAN VIEW



DEPARTMENT OF ENVIRONMENTAL RESOURCES
 Approved By: *[Signature]*
 Date: 11-21-90

REVISIONS

STORM DRAIN
 LOW FLOW
 STRUCTURE FOR
 EXTENDED DETENTION
 POND TYP.

SD 160.0

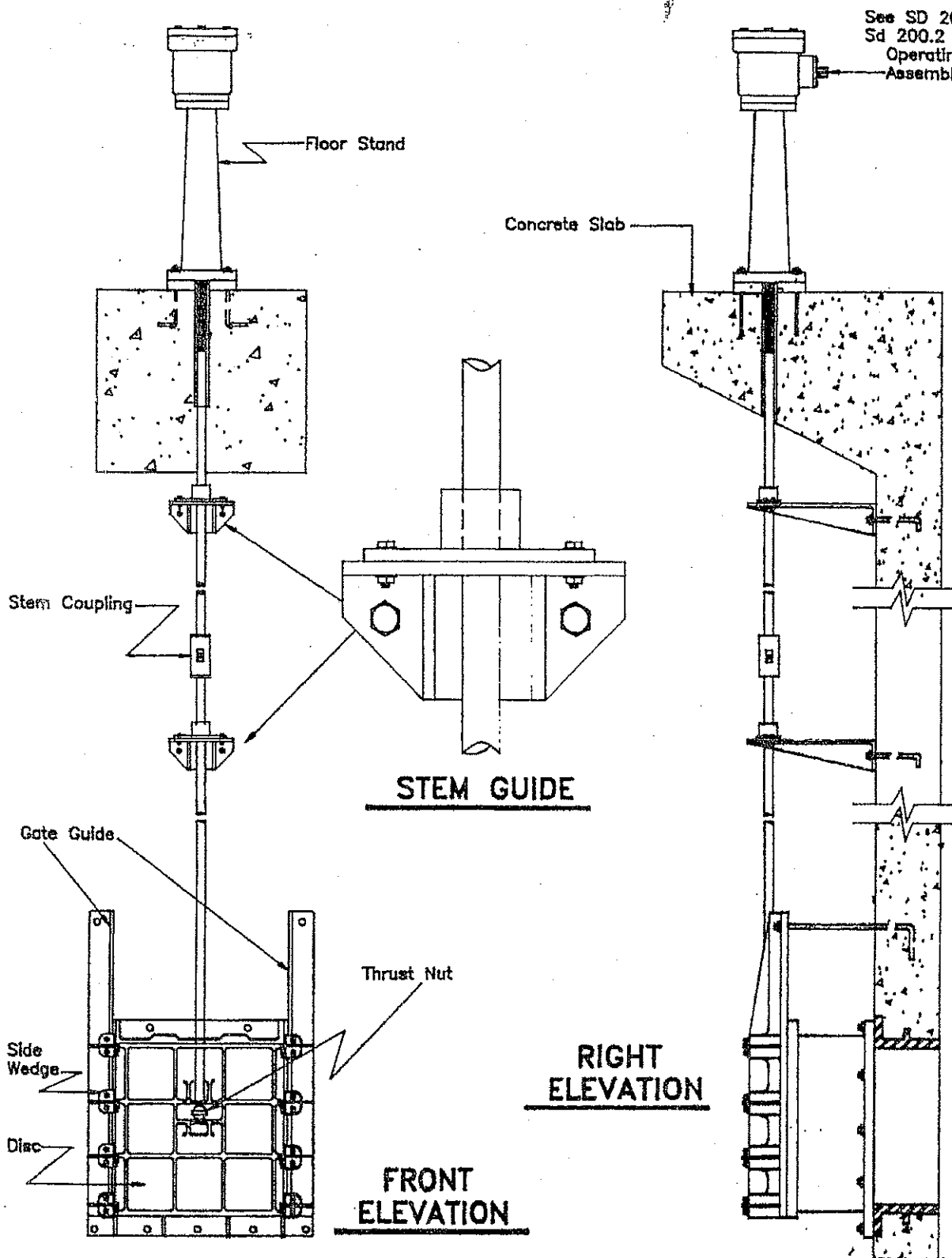

DEPARTMENT OF ENVIRONMENTAL RESOURCES Approved By: _____ Date: _____	REVISIONS	STORM DRAIN SLUICE GATE FOR DEWATERING SYSTEM	SD 200.0
	_____ _____ _____		

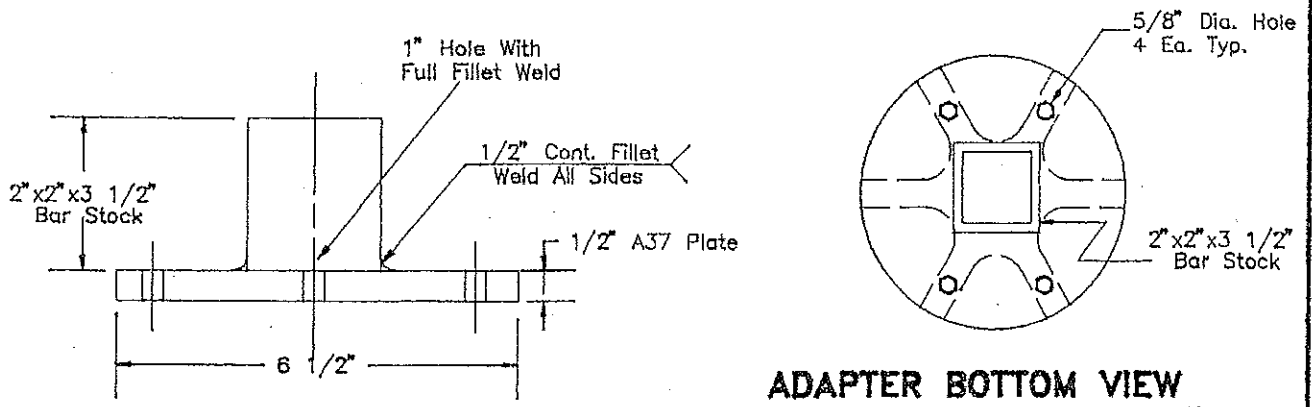
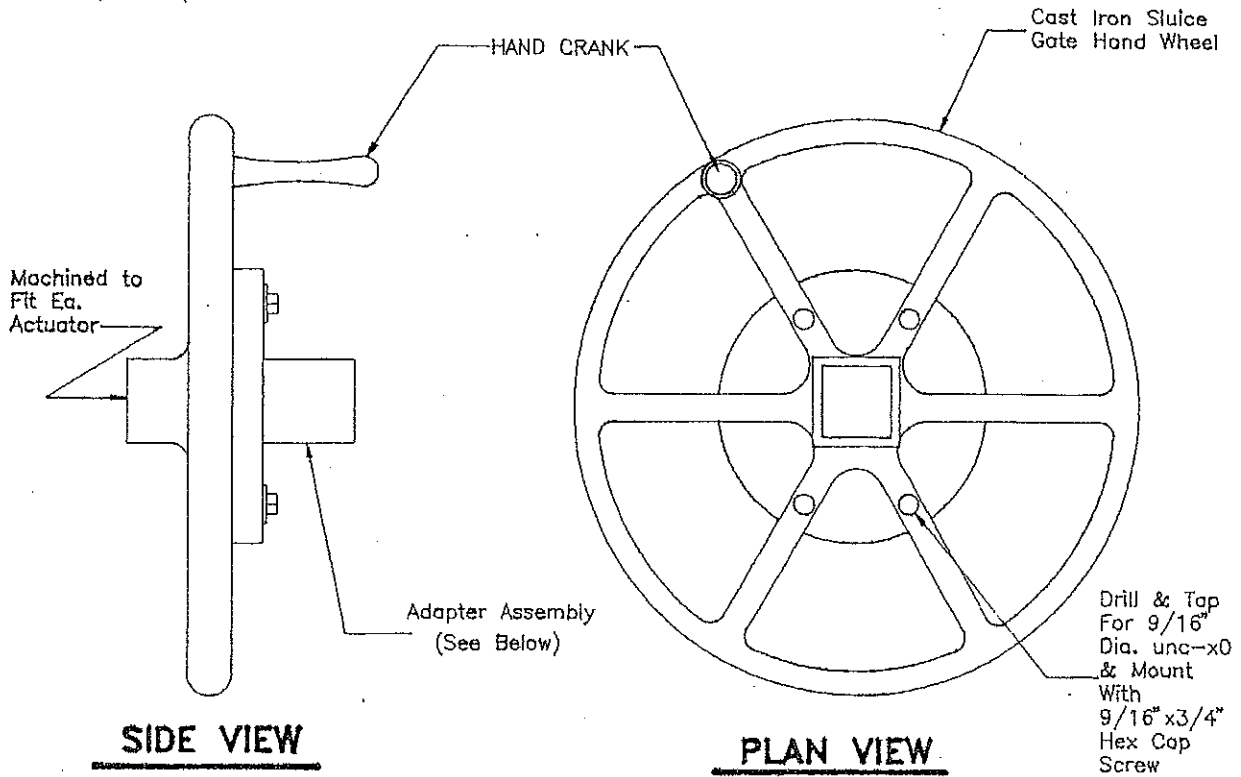

DEPARTMENT OF ENVIRONMENTAL RESOURCES

Approved By: _____

Date: _____

REVISIONS

STORM DRAIN
SLUICE GATE
WHEEL
ASSEMBLY

SD
200.1

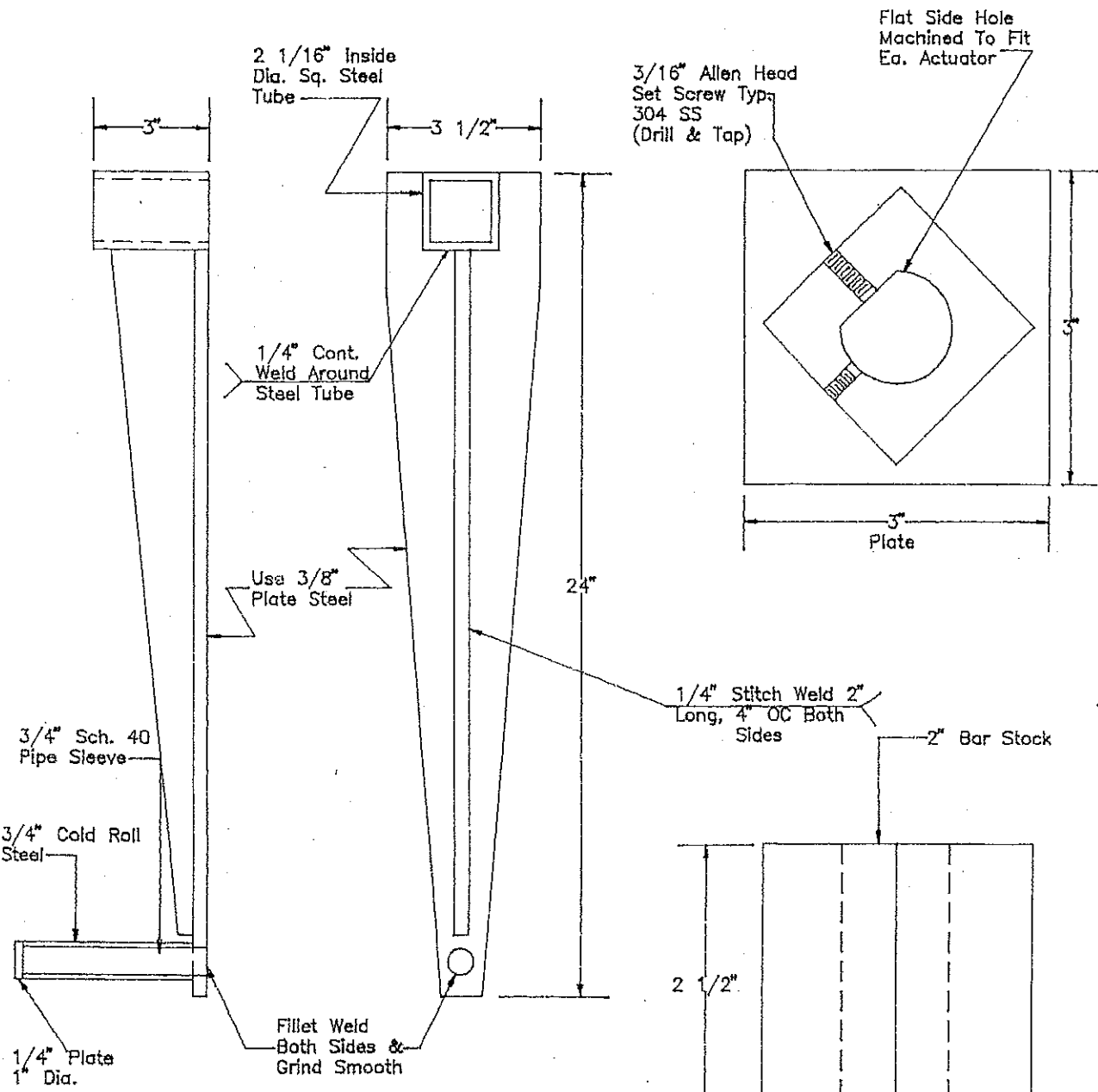

OPERATING WRENCH DETAIL

OPERATING NUT DETAIL

DEPARTMENT OF ENVIRONMENTAL RESOURCES Approved By: _____ Date: _____	REVISIONS	STORM DRAIN	SD
	_____ _____	OPERATING WRENCH & NUT ASSEMBLY FOR SLUICE GATE	200.2

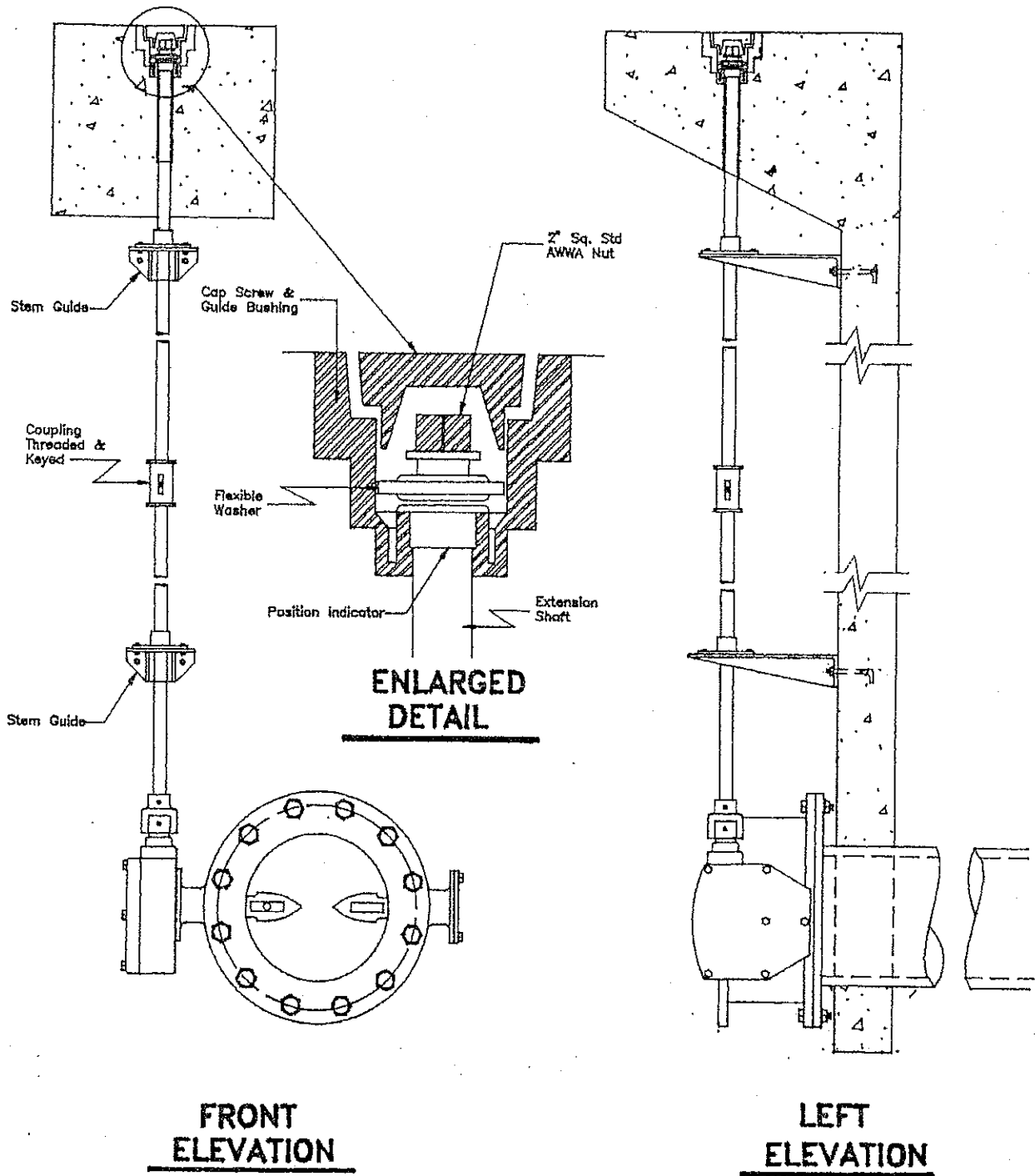

DEPARTMENT OF ENVIRONMENTAL RESOURCES

Approved By: _____

Date: _____

REVISIONS

STORM DRAIN CONTROL VALVE FOR DEWATERING SYSTEM

SD 210.0

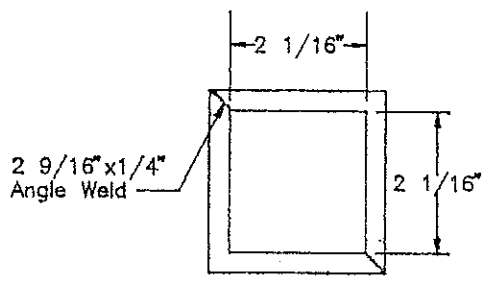
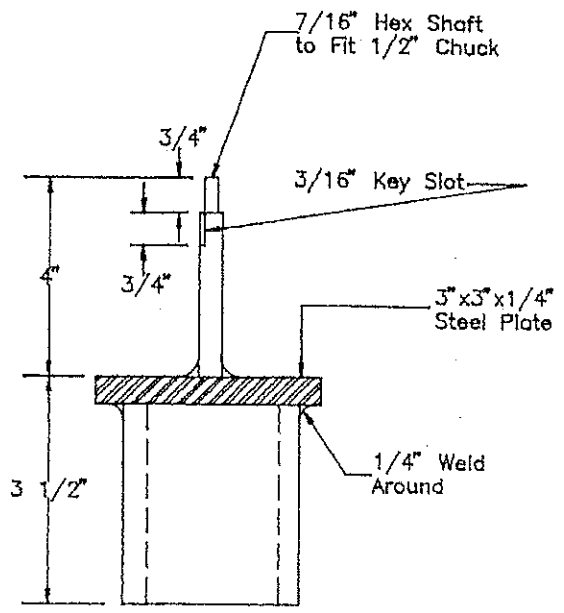
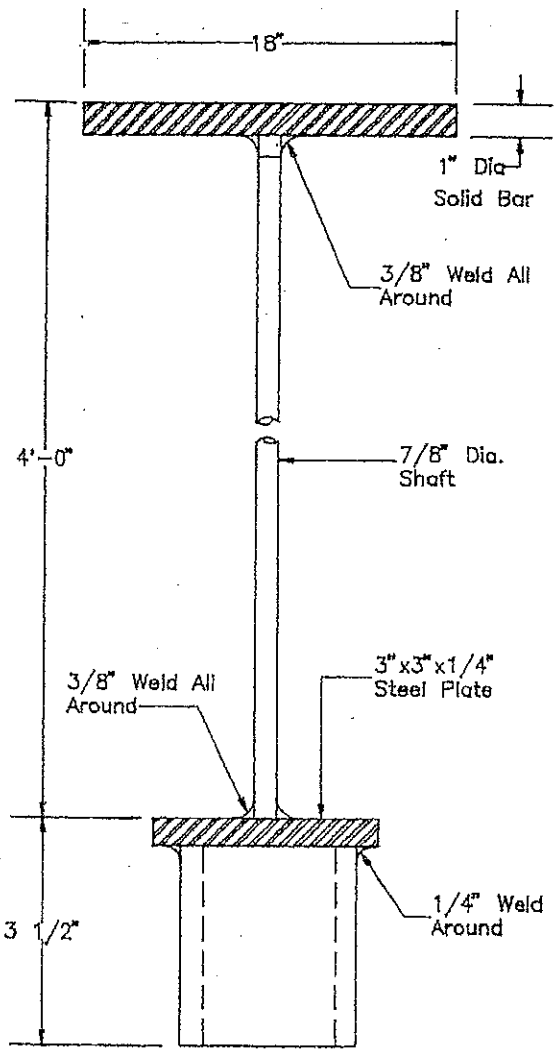

SOCKET ADAPTER FOR ELECTRIC DRILL

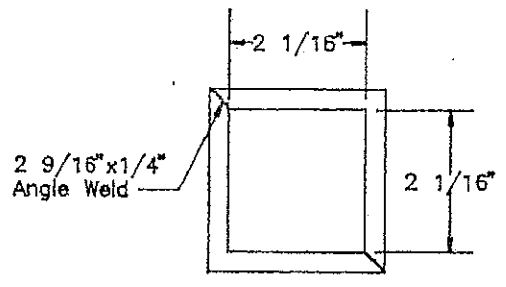

VALVE KEY DETAIL

DEPARTMENT OF ENVIRONMENTAL RESOURCES Approved By: _____ Date: _____	REVISIONS	STORM DRAIN	SD
	_____ _____ _____	VALVE KEYS	210.1

NEVER CUT LEADERS OFF

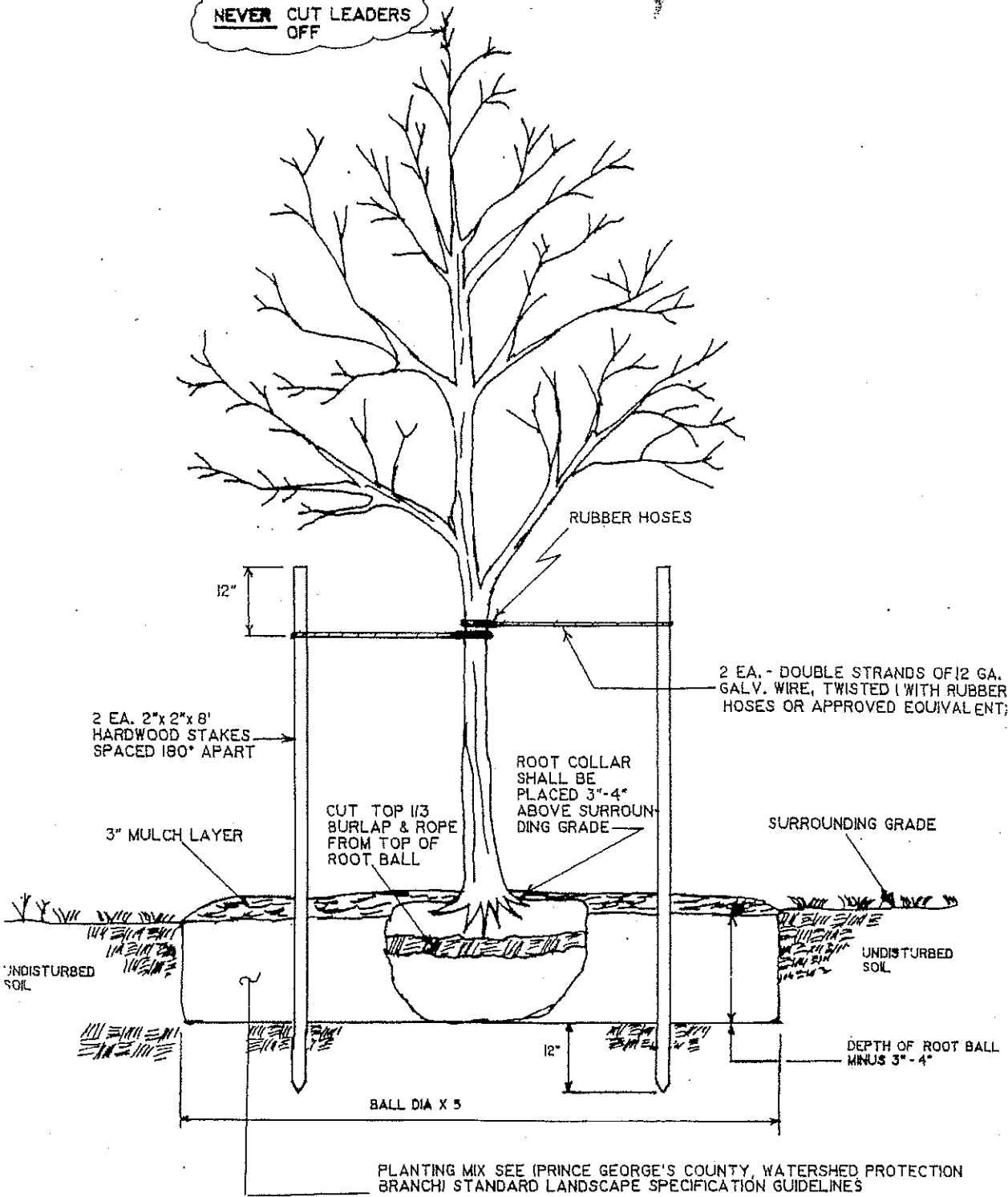

PLANTING MIX SEE (PRINCE GEORGE'S COUNTY WATERSHED PROTECTION BRANCH) STANDARD LANDSCAPE SPECIFICATION GUIDELINES



DEPARTMENT OF ENVIRONMENTAL RESOURCES
Approved By: *[Signature]*

Date: 11-21-90

REVISIONS

LANDSCAPING
DECIDUOUS AND
EVERGREEN
TREE PLANTING

LS
10.0

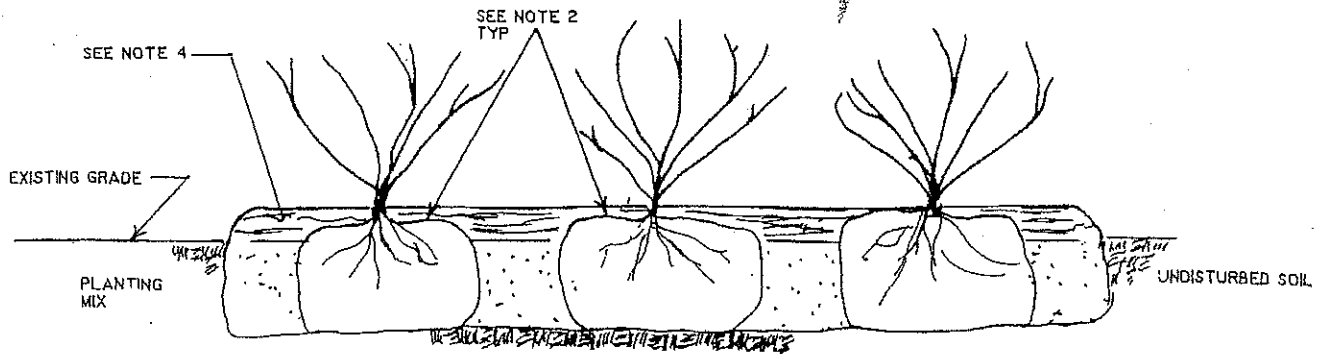

SHRUB BED PLANTING DETAIL

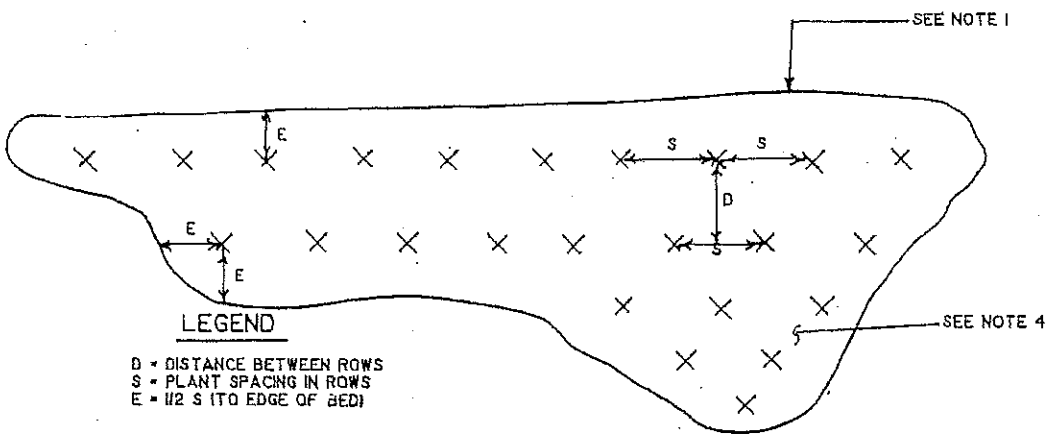

LEGEND
 D = DISTANCE BETWEEN ROWS
 S = PLANT SPACING IN ROWS
 E = 1/2 S (TO EDGE OF BED)

SHRUB & PERENNIAL BED DETAIL

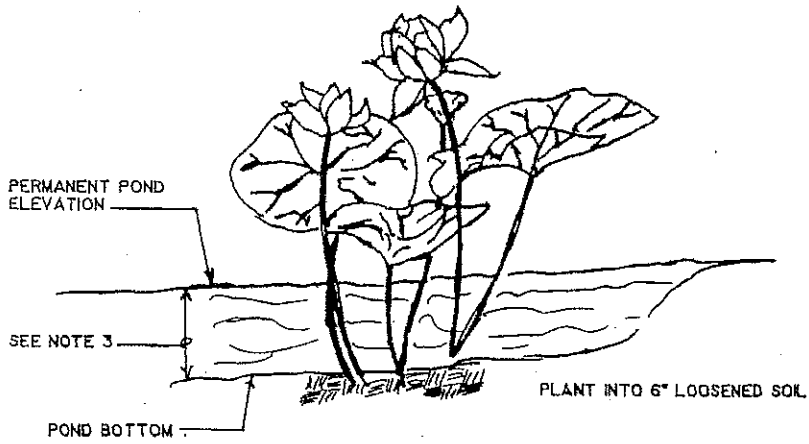

NOTES:

1. SPADE EDGE PERIMETER OF BED
2. TOP OF ROOT BALL SHALL BE 2" ABOVE THE EXISTING GRADE.
3. PLANT DEPTH WILL VARY ACCORDING TO PLANT TYPE (SEE LS 30.0)
4. THE ENTIRE BED SHALL BE COVERED TO A DEPTH OF 3" WITH MULCH.

AQUATIC PLANTING DETAIL

 <p>DEPARTMENT OF ENVIRONMENTAL RESOURCES Approved By <i>[Signature]</i> Date: 11-21-90</p>	<p>REVISIONS</p>	<p>LANDSCAPING</p>	<p>LS 20.0</p>
	<p> </p>	<p>SHRUB PLANTING</p>	
	<p> </p>		
	<p> </p>		

PLANT SCHEDULE

SYMBOL	BOTANICAL / COMMON NAME	QUANT.	SIZE	ROOT	SPACING	REMARKS
AR	Acer rubrum / RED MAPLE	10	2 1/2 CAL	B & B	AS	
PS	Pinus strobus WHITE PINE	6	6' - 8' HGT	B & B	AS	
IO	Ilex opaca / AMERICAN HOLLY	3	6' - 8' HGT	B & B	AS	2 Female, 1 Male
MV	Magnolia virginiana / SWAMP MAGNOLIA	5	6' - 8' HGT	B & B	AS	
EL	Elaeagnus umbellata AUTUM OLIVE	4	18' - 24' SPR	CG	AS	
CO	Cephalanthus occidentalis BUTTONBUSH	10	18' - 24' SPR	CG	6' O.C.	WET CULTIVATED PLANT BETWEEN 125.0 - 128.0 EL.
AC	Acorus calamus / SWEET FLAG	150		BR	2' O.C.	WET CULTIVATED PLANT BETWEEN 127.5 - 128.0 EL.
SL	Sagittaria arifolia DUCK POTATO	300	QUART	CG	2' O.C.	WET CULTIVATED PLANT BETWEEN 126.5 - 128.0 EL.

LEGEND

- CAL = CALIPER
- HGT = HEIGHT
- SPR = SPREAD
- B&B = BALLED & BURLAPPED
- CG = CONTAINER GROWN
- BR = BAREROOT
- AS = AS SHOWN



DEPARTMENT OF ENVIRONMENTAL RESOURCES
Approved By:

[Signature]
Date: 11-21-90

REVISIONS

LANDSCAPING.
TYPICAL
PLANT SCHEDULE

**LS
30.0**

$n = .013$

Capacity

Pipe Size (in)	Pipe Size (ft)	Area (sf)	K	Capacities (cfs) at Various Slopes								
				0.50	1.0	2.0	3.0	4.0	5.0	7.5	10.0	
12	1.00	0.79	35.7	3	4	5	6	7	8	10	11	
15	1.25	1.23	64.7	5	6	9	11	13	14	18	20	
18	1.50	1.77	105.3	7	11	15	18	21	24	29	33	
21	1.75	2.41	158.8	11	16	22	28	32	36	43	50	
24	2.00	3.14	226.8	16	23	32	39	45	51	62	72	
27	2.25	3.98	310.5	22	31	44	54	62	69	85	98	
30	2.50	4.91	411.2	29	41	58	71	82	92	113	130	
33	2.75	5.94	530.2	37	53	75	92	106	119	145	168	
36	3.00	7.07	668.7	47	67	95	116	134	150	183	211	
42	3.50	9.62	1009	71	101	143	175	202	226	276	319	
48	4.00	12.57	1440	102	144	204	249	288	322	394	455	
54	4.50	15.90	1972	139	197	279	342	394	441	540	624	
60	5.00	19.63	2612	185	261	369	452	522	584	715	826	
66	5.50	23.76	3367	238	337	476	583	673	753	922	1065	
72	6.00	28.27	4247	300	425	601	736	849	950	1163	1343	
84	7.00	38.48	6407	453	641	906	1110	1281	1433	1755	2026	
96	8.00	50.27	9147	647	915	1294	1584	1829	2045	2505	2893	

$$\text{Capacity} = K \sqrt{S}$$

$$S_{\min} = \left(\frac{Q}{K} \right)^2$$

$$K = \frac{1.49}{.013} A R^{2/3}$$

$$T_{11} = \frac{L}{V}$$

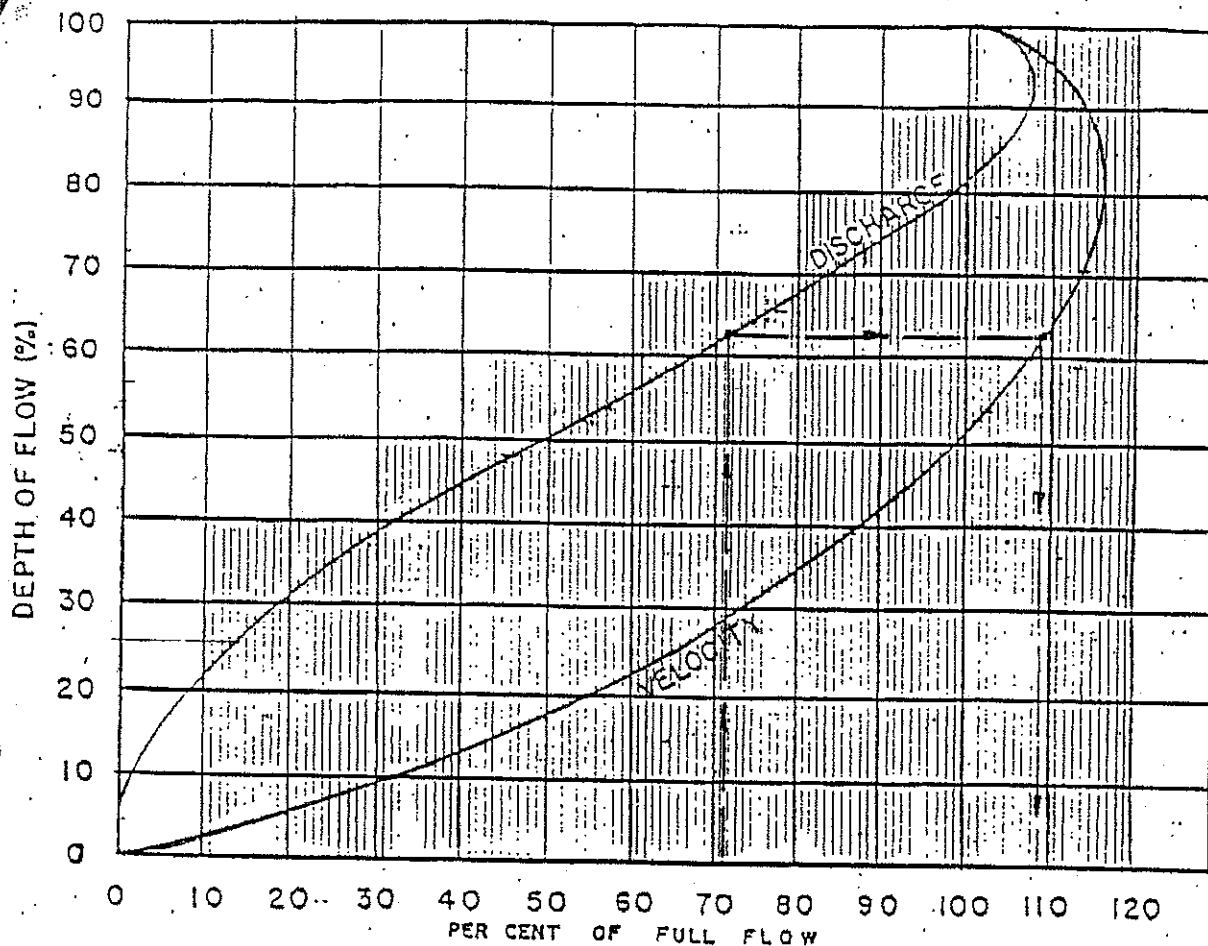

HYDRAULIC ELEMENTS OF
CIRCULAR SECTION APPROX.

To get partial flow depth and partial flow velocity:

1. Start with actual Q (Q_a), pipe diameter, pipe area (A), n value and actual slope (S)
2. Look up conveyance (K) for pipe size and n value.
3. Calculate capacity (Q_c) of pipe using K & S. $Q_c = K \sqrt{S^3}$
4. Calculate velocity at capacity using full pipe area. $V_c = Q_c / A$
5. Go into graph on horizontal axis with Q_a / Q_c
6. Read vertically until discharge curve is intersected.
7. Read horizontally to left axis to get Depth %
Partial Flow Depth = Depth % x pipe diameter
8. Read horizontally to right until velocity curve is intersected.
9. Read down to horizontal axis to get Velocity %
10. Partial Flow Velocity. (V_p) = Velocity % x V_c

Example:

- | | |
|--|---|
| <ol style="list-style-type: none"> 1. Actual Q = 15 cfs
18" RCP @ 4% 2. K = 105.3 3. $Q_c = 105.3 \sqrt{.04^3} = 21.1$ cfs 4. $V_c = 21.1 / 1.77 = 11.9$ fps | <ol style="list-style-type: none"> 5. $Q_a / Q_c = 15.0 / 21.1 = .71$ 6/7. Depth % = 63
Depth = .63 x 18" = 11.3" 8/9. Velocity % = 109 10. $V_p = 1.09 \times 11.9 = 13.0$ fps |
|--|---|

PIPE SIZE (inches)	LENGTH OF JOINT (inches)	$x = \frac{1}{3}$ JOINT (feet)	2 x WALL THICKNESS (feet)	$R = \frac{D + 2 \text{ thickness}}{\frac{x}{L}} + \frac{D}{2}$			
				PIPE LENGTH (feet)			
				4'	5'	6'	8'
27	3 $\frac{1}{8}$.0868	.54	130	161	194	256
30	3 $\frac{3}{8}$.0938	.58	132	165	199	265
33	3 $\frac{5}{8}$.1007	.62	135	169	203	269
36	3 $\frac{3}{4}$.1042	.66	142	177	212	283
42	4	.1111	.76	155	194	232	308
48	4 $\frac{1}{4}$.1180	.84	166	207	248	329
54	4 $\frac{1}{2}$.1250	.92	179	219	263	349
60	5	.1389	1.00	177	218	261	340
66	5 $\frac{1}{4}$.1458	1.08	184	228	272	364
72	5 $\frac{1}{2}$.1528	1.16	189	238	284	378
78	6	.1667	1.24	189	235	281	376
84	6 $\frac{1}{4}$.1736	1.34	196	246	292	388
90	6 $\frac{3}{4}$.1875	1.42	194	241	288	384
96	7 $\frac{1}{4}$.2014	1.50	192	238	289	378
102	7 $\frac{5}{8}$.2118	1.58	193	241	288	382
108	7 $\frac{7}{8}$.2187	1.66	200	249	297	395
120	8 $\frac{1}{4}$.2292	1.84	212	264	314	419

MINIMUM RADIUS OF CURVATURE
ON CENTERLINE OF PIPE

D. M. G. 1967

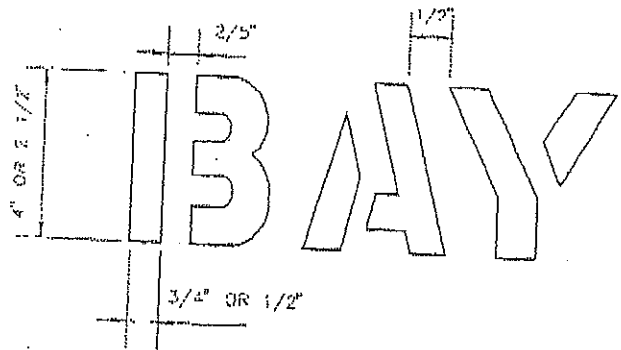

SAMPLE
NOT TO SCALE

NOTE

1. THE WORDS "CHESAPEAKE BAY DRAINAGE" AND "DON'T DUMP" MUST BE PLACED ON THE ARMOR CHANNEL OF THE COUNTY'S PUBLIC AND PRIVATE STORM DRAIN INLETS.
2. GRAY RUST-PROOFING NONTOXIC PAINT FOR THE BACKGROUND.
3. BLUE ENAMEL SPRAY NONTOXIC PAINT FOR LETTERS.
4. FOR OTHER SPECIFICATIONS, REFER TO MANUFACTURER'S INSTRUCTIONS.



DEPARTMENT OF
ENVIRONMENTAL RESOURCES

APPROVED BY: _____ DATE: _____
 Sign E. Wilderich, P.E.
 Assoc. Director

REVISION
 JAN. 2001

STORM DRAIN
 SIGN STENCIL

SD
 82.0